

## CONTROL PANEL PARTS

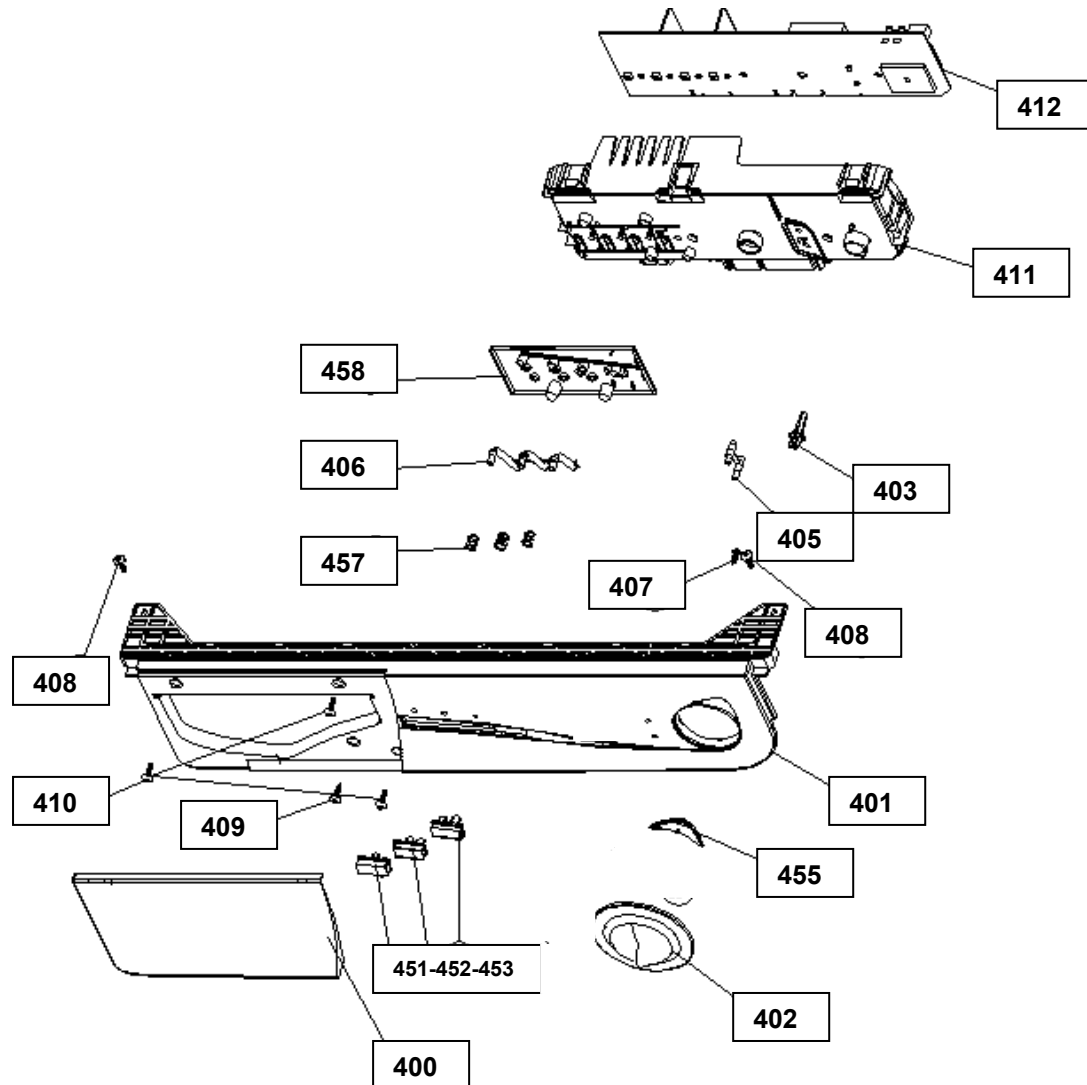

NO	PART NAME	QUANTITY
400	DETERGENT DRAWER COVER	1
401	CONTROL PANEL	1
402	PROGRAMME ADJUSDMENT KNOB	1
403	BUTTON SHAFT(PROGRAMME)	1
451	SELECTION BUTTON-ONE	1
452	SELECTION BUTTON-TWO	1
453	SELECTION BUTTON-THREE	1
405	DOUBLE LIGHT CARRIER	1
455	TRANSPARENT PIECE(PROG)	1
457	BUTTON SPRING	3
406	QUARTET LIGHT CARRIER	1
458	BUTTON COVER	1
407	SCREW PT 3,5*9	1
408	SCREW ST 4,2*9,5 TS 432	2
410	SCREW PT 4*14	3
409	SCREW ST 4,2*13 TS 432	1
411	PCB BOX	1
412	ELECTRONIC CARD(PCB)	1
500	CONTROL PANEL GROUP	1

**400-401-402-403-413-414-451-452-453-454-455-456-457-406-458-407-411-412--- CONTROL PANEL GROUP**

## FRONT PANEL PARTS

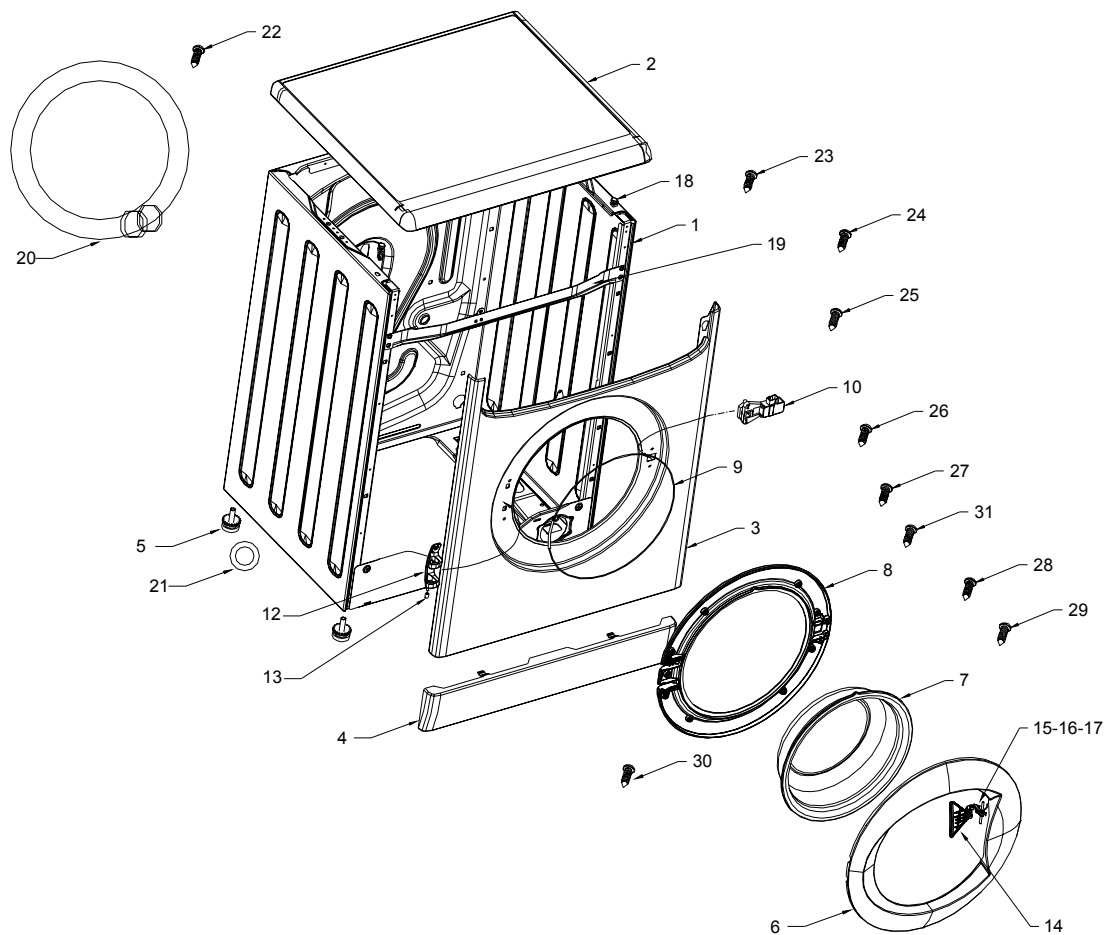

NO	PART NAME	QUANTITY
1	BODY GROUP PAINTED	1
2	UPPER TRAY GROUP	1
3	FRONT PANEL GROUP PAINTED	1
4	PLASTIC KICKPLATE	1
5	ADJUSTABLE FOOT GROUP	4
6	DOOR OUTSIDE PLASTIC	1
7	DOOR GLASS	1
8	DOOR INSIDE PLASTIC	1
9	HOUSING FRAME BELLOW CLIP	1
10	DOOR LOCK	1
12	HINGE	1
13	HINGE BUSHING	1
14	HANDLE	1
15	HANDLE SPRING	1
16	DOOR HANDLE TONGUE PIM	1
17	DOOR LOCK TONGUE	1
18	UPPER TRAY DROP PLASTIC	2
19	MIDDLE SUPPORT BRACKET GROUP	1
20	WATER ENTRY HOSE GROUP	1
21	ADJUSTED FOOT ADJUST STAMP PLS.	4
22	SCREW ST 5,5*13 TS 432	2
23	SCREW ST 4,2*9,5 TS 432	4
24	SCREW ST 4,2*32	1
25	SCREW ST 4,2*16 TS 432	5
26	SCREW ST 4,2*9,5 TS 432	2
27	SCREW ST 4,8*9,5 TS 432	2
28	SCREW ST 3,5*16	7
29	SCREW PT 3,5*12	2
30	SCREW TT M4*8	2
31	SCREW ST 4,2*9,5 TS 432	2
50	DOOR GROUP	1

8-28-29-7-15-16-17-14-6---- DOOR GROUP

## WASHING GROUP PARTS

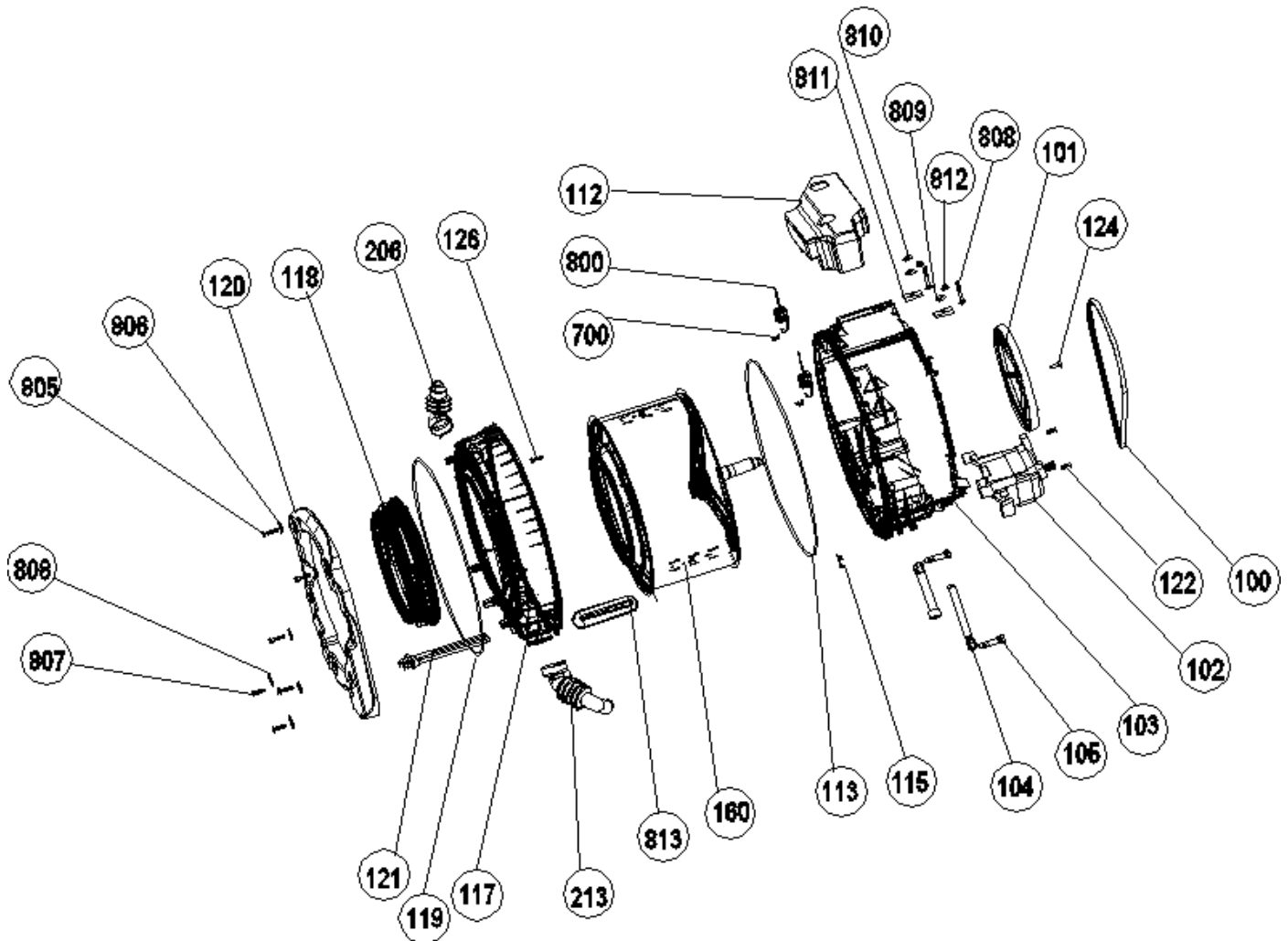

NO	PART NAME	
103	REAR TUB GROUP	1
117	FRONT TUB	1
160	DRUM GROUP	1
102	MOTOR	1
113	TUB SEAL	1
101	DRIVEN PULLEY	1
100	BELT	1
122	SCREW M 8*25	4
206	TUB ENTERANCE WITH BELLOW HOSE	1
118	TUB BELLOW SEAL	1
126	SCREW PT 6*25	19
805	SCREW PT 8*40	4
806	WASHER 8,4*28*3	4
808	WASHER 37*23*2	2
807	SCREW PT 8*34	2
119	TUB BELLOW CLIP	1
120	FRONT CONCRETE WEIGHT	1
121	RESISTANCE GR	1
115	RESISTANCE FIXING WIRE	1
104	SHOCK ABSORBER	1
213	TUB EXIT WITH BELLOW HOSE	1
124	SCREW PT 8*25	1
700	TUB HANGER SPRING PART	2
800	HANGER SPRING	2
808	SCREW M8*65	3
809	WASHER 8,5*35*3	3
811	UPPER CONCRETE SUPPORT SHEETIRON PART	2
812	M8 NUT	2
813	PLASTIC LIFTER	3
810	WASHER 9*30*3(DIN 6796)	3
112	UPPER CONCRETE WEIGHT	1
105	SHOCK ABSORBER PIM	2

## DETERGENT DRAWER GROUP

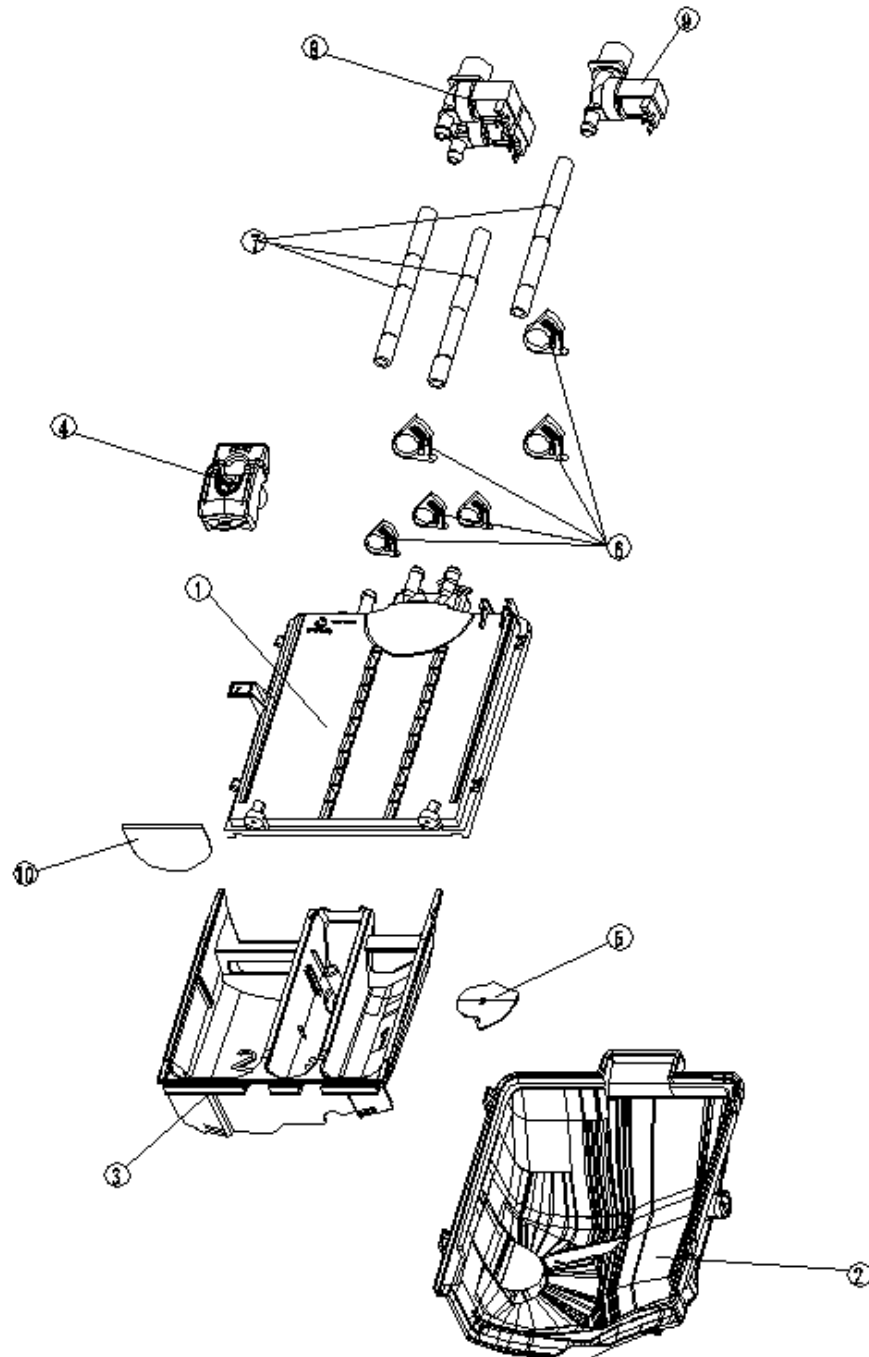

### 9-DOUBLE WATER INLET IN MACHINES

NO	PART NAME	
1	WATER DISTRIBUTION PLATE GROUP	1
2	DETERGENT DRAWER HOUSING	1
3	DETERGENT DRAWER	1
4	SIPHON COVER	1
5	STEAM CONSERVATIVE	1
6	HOSE HANDCUFFS	6
7	VALVE-DETERGENT BOX HOSE	3
8	VALVE(TWO EXIT)	1
9	VALVE(ONE EXIT)	1
10	LIQUID DETERGENT LEVEL PLATE	1
1-2-3-4-5	DETERGENT BOX GROUP	1
1-2-3-4-5-6-7	DETERGENT BOX GROUP/HOSE	1
1-2-3-4-5-6-7-8	DETERGENT BOX GROUP/FULL	1

### PRESSURE SWITCH HOSE GROUP

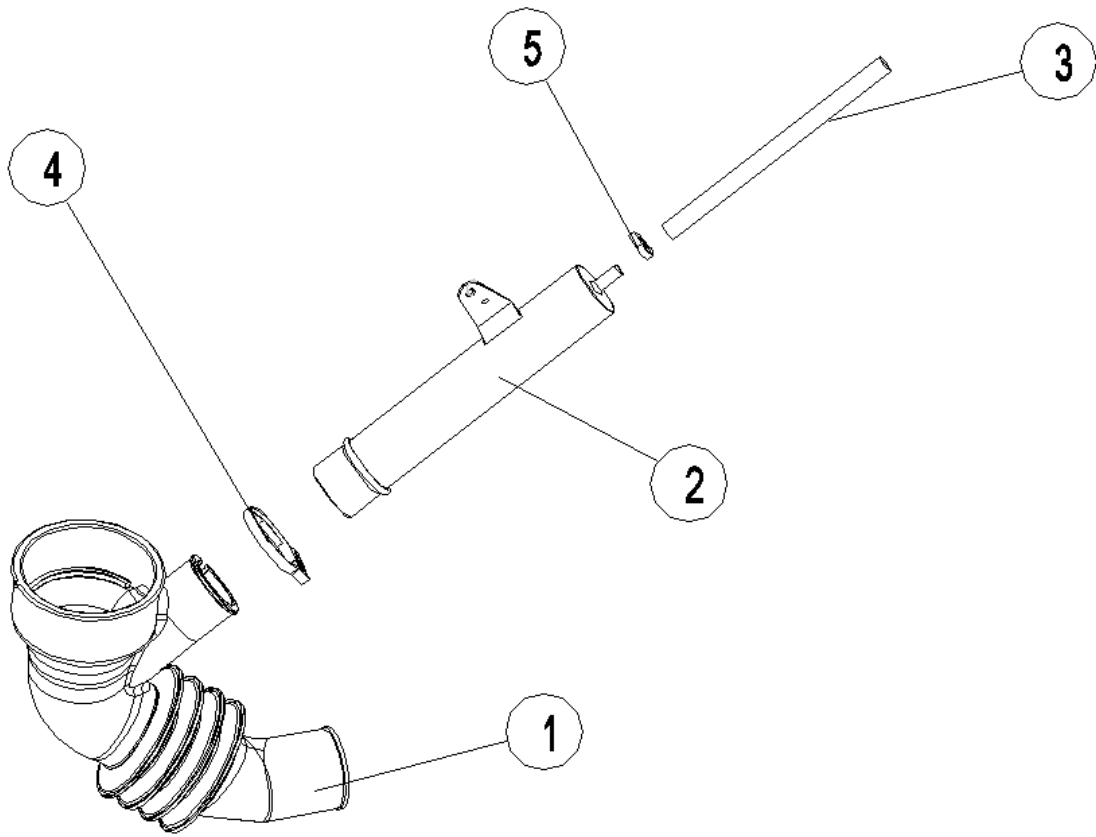

NO	PART NAME	
1	TUB EXIT WITH BELLOW HOSE	1
2	PRESSURE SWITCH WATER RESERVOIR	1
3	PRESSURE SWITCH HOSE	1
4	HOSE HANDCUFFS	1
5	HOSE HANDCUFFS	1
1-2-3-4-5	PRESSURE SWITCH HOSE GROUP	1

## BODY GROUP PARTS

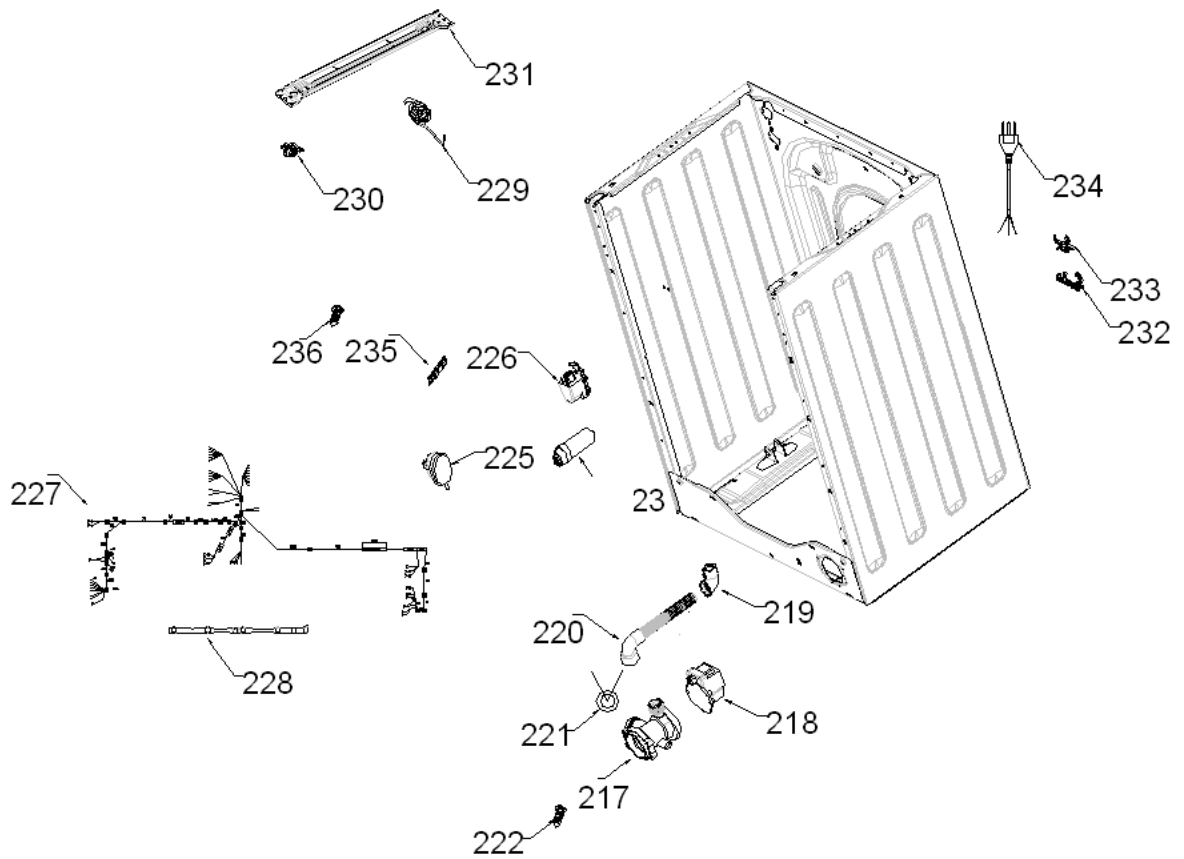

NO	PART NAME	QUANTITY
217	DRAIN PUMP FILTER GROUP	1
218	DRAIN PUMP	1
219	DRAIN HOSE BODY EXIT PLS	1
220	DRAIN HOSE	1
221	HOSE HANDCUFFS Ø38,8	1
222	SCREW ST 4,2*9,5	4
225	PRESSURE SWITCH	1
226	PARASITE FILTER	1
227	CABLE HARNESS	1
228	CABLE PORTER PLS	1
229	HANGER SPRING	2
230	HANGER SPRING PLS.	2
231	SPRING HANGER SHEETIRON	1
232	DRAIN HOSE AND CABLE HOLDING PLS.	2
233	DRAIN HOSE HOLDING PLS	2
234	POWER CORD GROUP	1
235	PRESSURE SWITCH CARRIER	1
236	SCREW 4.2*9.5	1