

DEHUMIDIFIER

SERVICE MANUAL

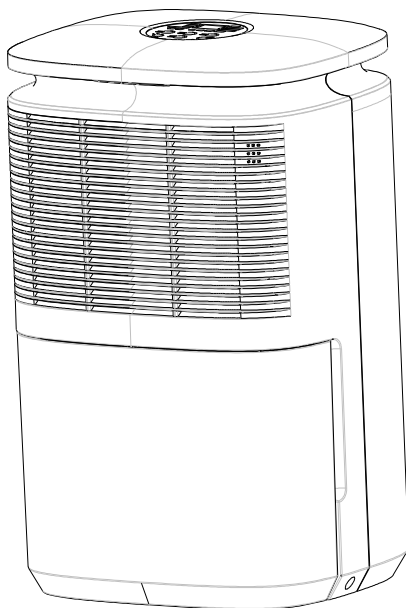

DEUMIDIFICATORE LILIUM 11/13

Model : FDD10/12-5031BR5 (-1)

TABLE OF CONTENTS

Description of structure	1
Disassembly method	3
Interior layout	5
Principle of electrical control and running characteristics	6
Principle of refrigeration system	8
Trouble shooting guide	9
Specications	11
Explosive diagram	12

Description of structure

■ Body parts

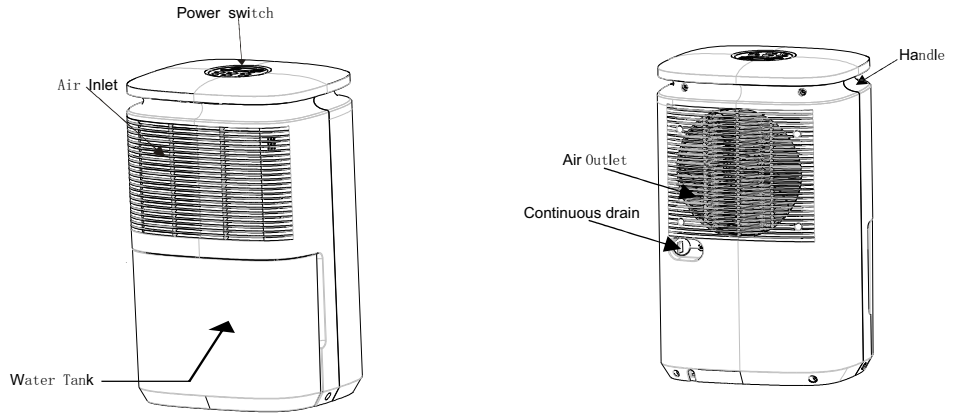

■ Accessories

1. Drain pipe

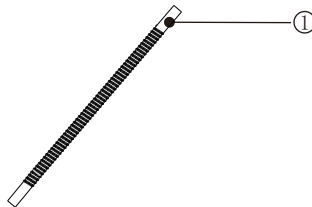

Description of structure

Control Panel

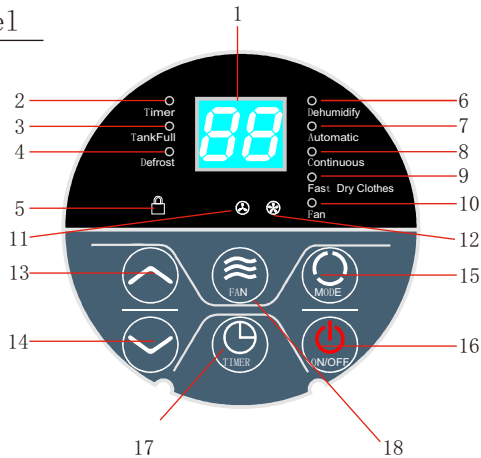

- | | |
|---------------------------|--------------------------------|
| 1. Display window | 10. Fan light |
| 2. Timing light | 11. Low wind light |
| 3. Tank Full light | 12. High wind light |
| 4. Defrost light | 13. Timer/humidity rise button |
| 5. Child lock light | 14. Timer/humidity drop button |
| 6. Dehumidify light | 15. Mode button |
| 7. Automatic light | 16. "⏻" button |
| 8. Continuous light | 17. Timer button |
| 9. Fast Dry Clothes light | 18. Fan button |

Disassembly method

■Tear down the machine as the following procedure:

1. Loosen the screw and pull out the water plug

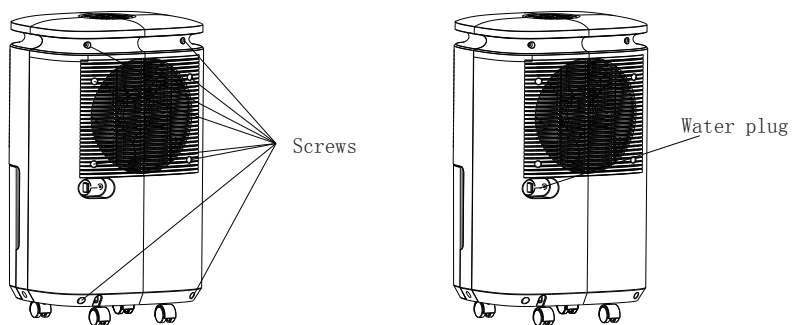

2. Open the top cover, back cover, and unplug the operation panel's docking plug.

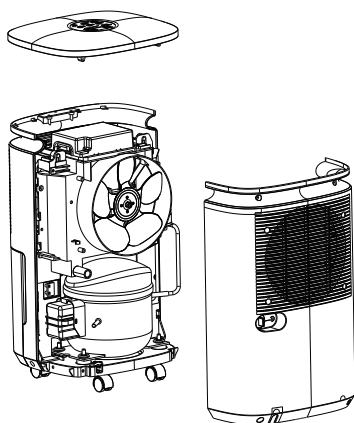

Disassembly method

3. Remove the water tank and remove the front cover screws

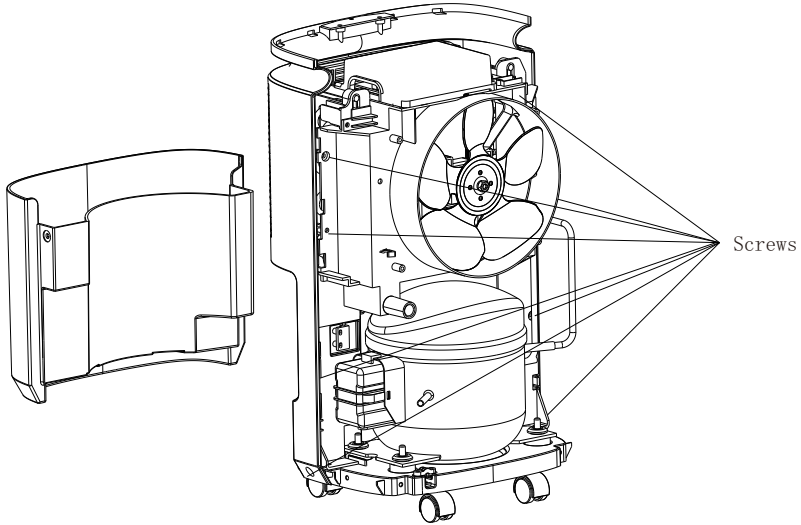

4. Remove the front cover according to the picture' s direction.

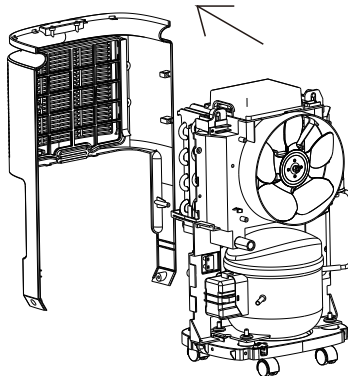

Interior layout

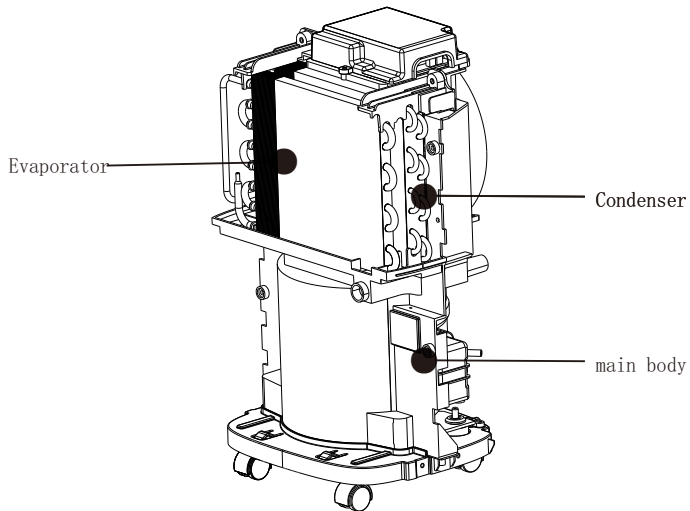
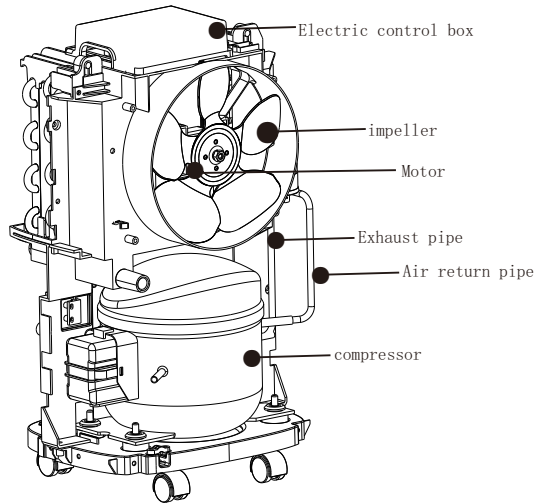

Principle of electrical control and running characteristics

Each mode working principle

1. Power Button:

This button can control the machine on and off;

2. Mode keys:

This button can enter the mode selection state, then the current mode will flash, press "↖" or "↙" key to select mode, the mode selection Press this button and then finished five seconds without operation will exit the mode selection and enter selected mode;

3. "↖" And "↙" keys:

This two buttons can be set for humidity and timing and mode conversion;

a. When humidity adjustment: adjust the humidity can be recycled at 30% -80%, adjusted margin of 5%; humidity dehumidification mode can only be adjusted;

b. When the timer time setting: The time can be set within 24 hours; only the timing off function, there is no time to open;

c. Mode selection: You can "Dehumidify", "Automatic ","Continuous" "Fast Dry Clothes" between "Fan" conversion; the corresponding indicator light off;

4. Fan from the key:

This button can adjust the wind speed, wind speed in the "low", "high-speed" between conversion; the corresponding indicator light off;
NOTE: This key is only valid when the "Fan" and "dehumidify" mode;

5. Timer button:

a. Button to enter the timer setting status, and two 8-screen timer lamp flashes, then press "↖" or "↙" key to set the timing of time; time is 1-24 hours;

b. If you set the time to "0", then press this button or 5 seconds no operation is automatically timed exit; if the set time is not "0", then press this button or 5 seconds without operation will automatically enter the time off work state; setting End After 5 seconds two 8-screen return humidity display;

c. When there are regular, timed lights; when no timing at which the lamp;

d. Under then existing timing premise, pressing this key displays the current time remaining;

6. Child Lock Key:

a. While holding down the "↖" key and "↙" button for 3 seconds, it will enter the "child lock" mode, the corresponding indicator lights up in this mode, press any key invalid;

b. In the "Child Lock" state, while holding down the "↖" key and the "↙" button for 3 seconds, it will exit the "child lock" mode, the corresponding indicator exterminate;

7. Each mode Description:

a. "Dehumidify" mode: When 3% humidity less than the set humidity, the compressor is off, fan three minutes after closing; when the ambient humidity is 3% more than the set humidity, the compressor and the fan turned on; the fan speed is adjustable;

b. "Automatic" mode: automatically set humidity of 55%, the wind speed is automatically adjusted to maintain the humidity at 55%;

c. "Continuous" mode: humidity can not be set, fixed speed wind speed, press continuously open;

d. "Fast Dry Clothes" mode: humidity can not be set, wind speed fixed speed, press continuously open;

e. "Fan" mode: humidity can not be set, adjustable speed, press closed;

Principle of electrical control and running characteristics

● Notes on operation

1. If the tank is full, the unit will automatically stop and the water full indicator will illuminate to indicate that the user has taken water.
2. Allow 3 minutes for the compressor to restart dehumidifying
If you turn the Dehumidifier off and immediately restart it, allow three minutes for the compressor to restart. There is an electronic device in the unit that keeps the compressor off three minutes for protection.

● Circuit diagram

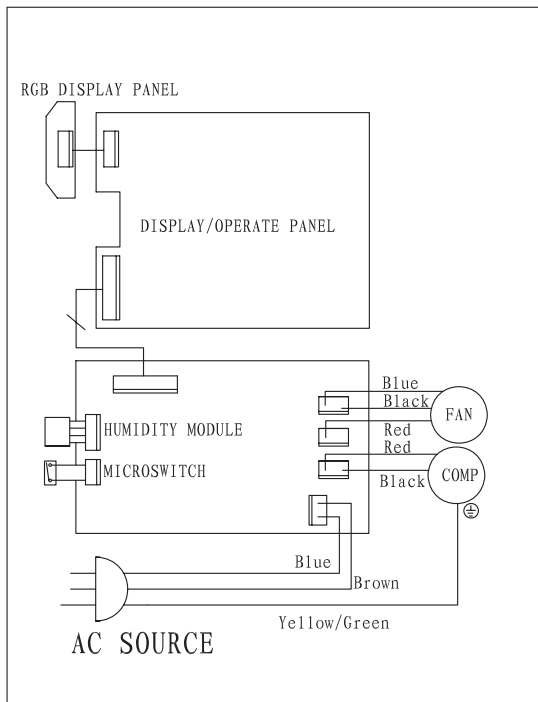

Principle of refrigeration system

Dehumidifying principle of dehumidifier:

When temperature is decreased to the temperature point of dew, water vapor in humid air will condensate. Dehumidifier is dehumidifying the air by using this principle. During operation of the system, air will pass through evaporator and condenser in turn and then be discharged due to centrifugal blade. When the air is passing through evaporator, refrigerant will absorb the heat in air to let its temperature decrease to the temperature point of dew, water vapor in air will condensate. Condensate water comes into water tank through water tray, or is discharged directly through drainage hose. The saturated low-temperature air passed through the evaporator will absorb the heat when flowing along the condenser, and then become the dry air. Under normal condition, the nearby air will become warm during operation of dehumidifier.

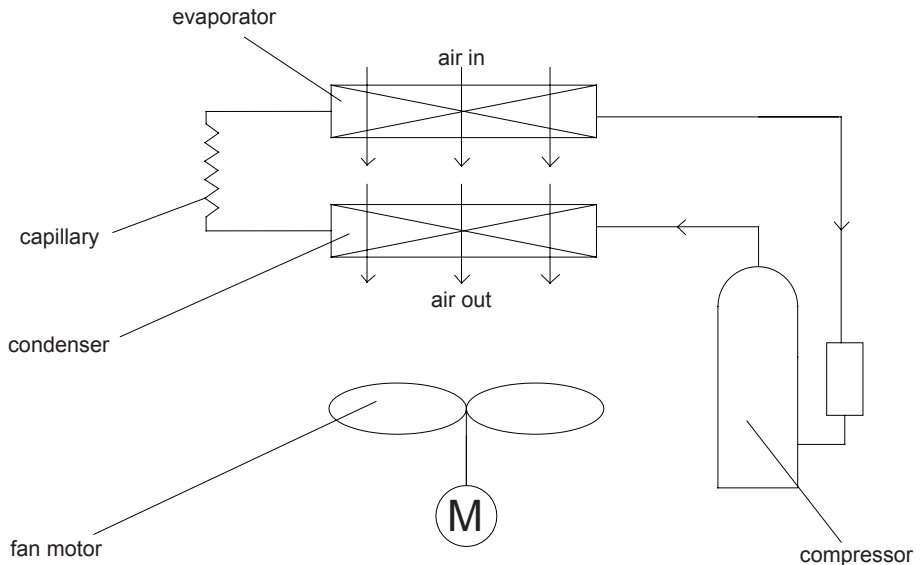

Trouble shooting guide

1.The unit can not start up

Possible causes	Dehumidifier status	Troubleshooting
No power supply.	Power indicator is not on after the unit is energized.	Confirm whether it's due to power failure. If yes, wait for power recovery. If not, check power supply circuit and make sure the power plug is connected well.
Poor connection between wiring terminals	Power indicator is not on after the unit is energized.	Check the circuit according to wiring diagram and connect wire properly; ensure each wiring terminal contacted firmly.
There is electric leakage in the unit.	Circuit breaker jump off immediately after the unit is energized.	Make sure the unit is properly grounded; Make sure the wiring is correct; Check if the insulating layer of wires inside the unit and power cord is in good condition; if the layer is broken, please replace it.
Placing position of water tank is not correct. Tank is removed or the water is full.	Water-full indicator flashes.	Make sure the water tank is placed correctly.

2. Poor dehumidifying effect

Possible causes	Dehumidifier status	Troubleshooting
Set humidity is irrational.	Check the displayed set humidity.	Re-set the humidity.
Filter is blocked.	Check the filter.	Clean the filter.
Placing position of water tank is improper.	Check whether there have obstacles around the dehumidifier blocked the air outlet.	Make sure there' re no obstacles around the dehumidifiers.
Refrigerant is leaking.	Air outlet temperature is lower than normal temperature during dehumidifying period.	Find out the cause of leakage and solve the problem; charge refrigerant.
Malfunction of capillary.	Air outlet temperature is lower than normal temperature during dehumidifying period. If the refrigerant isn' t leaking, some parts of capillary are blocked.	Replace capillary.

3.Fan can' t operate

Possible causes	Dehumidifier status	Troubleshooting
Wrong wire connection, or poor connection.	Check the wiring status according to circuit diagram.	Connect wires according to wiring diagram to make sure all wiring terminals are connected firmly.
Needle stand of connection wire between mainboard and display board is loosened.	Check if the needle stand is loosened.	Reinsert the needle stand firmly.
Fan capacitor is broken.	Test the voltage between two ends of fan capacitor with universal meter and the value is 0.	Replace fan capacitor.
Power supply voltage is too low or too high.	Test the power supply voltage with universal meter. Make sure that the voltage is not higher than >264V or lower than 198V.	Apply voltage regulator.
Fan is broken.	The above situation is normal but the fan does not operate.	Repair or replace the fan.

Trouble shooting guide

4. Compressor can't operate

Possible causes	Dehumidifier status	Troubleshooting
Wrong wire connection, or poor connection	Check the wiring status according to circuit diagram.	Connect wires according to wiring diagram to make sure all wiring terminals are connected firmly.
Compressor relay on the mainboard is broken or the compressor needle stand is loosened.	Check if the relay is sucked in cooling mode.	Replace the mainboard with the same model.
Capacity of compressor is damaged.	Use universal meter to measure the resistance value of two contact points of capacitor. If the resistance value is too big or 0, the capacitor is damaged.	Replace the compressor capacity.
Coil of compressor is burnt out.	Test the resistance of the wiring poles of compressor with universal meter. If the resistance is in infinite or 0, it means it is broken.	Repair or replace compressor.
Cylinder of compressor is blocked.	The dehumidifying effect is poor after turning on the unit. The noise of compressor is big and the compressor is hot.	Repair or replace compressor.

5. Water leakage

Possible causes	Discriminating method (dehumidifier status)	Troubleshooting
Drainage pipe hasn't been installed correctly.	There are water leakage.	Eliminate the blocking objects inside the drainage channel. Connect the drainage pipe firmly.

6. Abnormal sounds and high vibration

Possible causes	Dehumidifier status	Troubleshooting
There is abnormal sound in some parts when just turning on or turning off the unit.	There's the sound of "PAPA".	Normal phenomenon. Abnormal sound will disappear after a few minutes.
There is abnormal sound in some parts when just turning on or turning off the unit.	Water-running sound can be heard.	Normal phenomenon. Abnormal sound will disappear after a few minutes.
There is touching sound of foreign objects or parts inside the unit.	The unit gives out abnormal sound.	Take out the foreign objects; adjust the position of each part inside the unit; tighten the connection screws; apply some damping gum on the touching parts.
Abnormal shake of compressor.	The unit gives out abnormal sound.	Adjust the support foot mat of compressor, tighten the bolts.
Abnormal sound inside the compressor.	Abnormal sound inside the compressor.	If add too much refrigerant during maintenance, please reduce refrigerant properly. Replace compressor for other circumstances.

Specifications

Model: FDD10-5031BR5(-1)

Power supply: AC220V-240V~ 50Hz

Dehumidifying capacity: 10L/day (30° C 80%)
5 L/day (27° C 60%)

Input power: 200W

Rated current: 1.25A

Water tank capacity: 2.2L

Net weight: 9.5kg

Overall dimensions: height 525mm, length 320mm, width 284mm

Application scope: 5-32° C

Refrigerant: R290

Model: FDD12-5031BR5(-1)

Power supply: AC220V-240V~ 50Hz

Dehumidifying capacity: 12L/day (30° C 80%)
6 L/day (27° C 60%)

Input power: 210W

Rated current: 1.26A

Water tank capacity: 2.2L

Net weight: 11kg

Overall dimensions: height 525mm, length 320mm, width 284mm

Application scope: 5-32° C

Explosive diagram

Serial number	English part name	Quanti	Serial number	English part name	Quanti
1	Decorative lights	1	21	Compressor	1
2	Front cover	1	22	Back cover	1
3	Float	1	23	Water plug	1
4	Water tank	1	24	Fan	1
5	Filter bracket	1	25	Fan fixed buckle	1
6	Plastic filter	1	26	Dry reed pipe	1
7	Filter plate	1	27	Main body	1
8	Evaporator	1	28	Power Board	1
9	Condenser	1	29	Upper Cover	1
10	Charge assembly	1	30	Operation board	1
11	Exhaust pipe	1	31	Electric cover box	1
12	Capillary	1	32	Control panel	1
15	Process pipe	1	33	Electrical box	1
16	Capillary nozzle	1	34	Motor	1
17	Casters	4	35	Clamp assembly	1
18	Chassis	1	36	Humidity Sensor	1
19	Pump foot bolt	4	37	Light board	1
20	Line pressing board	1			