

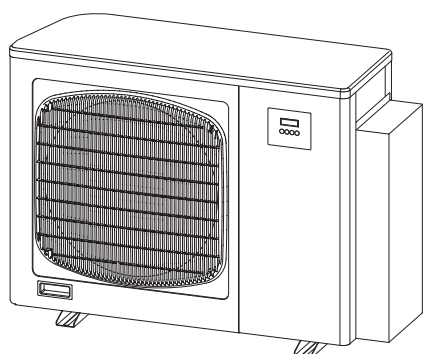
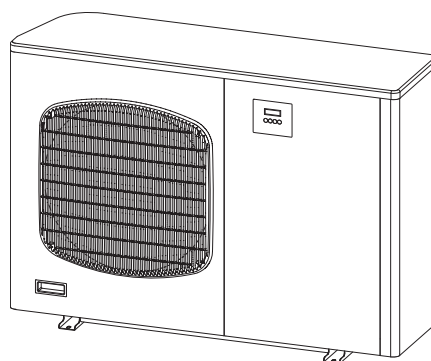
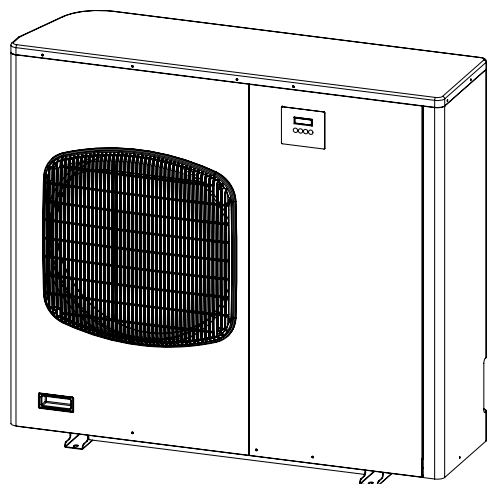
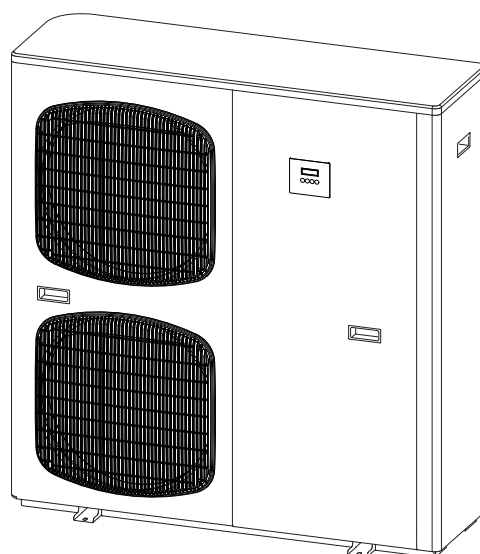

AIM

AIM06EMX**AIM08EMX****AIM11EMX
AIM11EMX3PH****AIM14EMX3PH**

**Inverter monoblock air to water heat pump
Medium temperature - R 410 A refrigerant**

**Pompa di calore monoblocco Inverter aria / acqua
Media temperatura - Fluido refrigerante R 410 A**

**Pompe à chaleur monobloc Inverter air / eau
Moyenne température - Fluide réfrigérant R 410 A**

1 - Installation location	4
2 - Generalities	5
3 - Connections	8
4 - System wiring diagrams	10
5 - Emix / Emix tank installation.	19
6 - System layout	22
7 - Starting	26
8 - Maintenance instructions	32
9 - Electrical diagrams	33
10 - Auto-diagnosis table.	39

REGULATION (EU) No. 517/2014 - F-GAS

The unit contains R410A, a fluorinated greenhouse gas with a global warming potential (GWP) of 2087.50. Do not release R410A into the atmosphere.

R410A - AIM06: 1.30 kg / 2.71 Tonn. CO2
 R410A - AIM08: 1.46 kg / 3.05 Tonn. CO2
 R410A - AIM11: 2.50 kg / 5.22 Tonn. CO2
 R410A - AIM14: 3.10 kg / 6.47 Tonn. CO2

PRODUCT INFORMATION

The year of production of this unit is indicated in the Nameplate (see figure below).

Power Supply:

SINGLE PHASE: 220 - 240 V / 1 / 50 Hz
 THREE PHASE: 380 - 415 V / 3N / 50 Hz

s/n: Y00000RR

Year of production
 example: 0=2020
 1=2021

Serial number

IMPORTANT!**Please read before installation**

Installation of these products must be carried out by qualified personnel in accordance with European regulations 303/2008 and 517/2014.

This system meets strict safety and operating standards.

For the installer or service person, it is important to install or service the system so that it operates safely and efficiently. To begin the warranty, the product must be started by a service center Argoclima S.p.A.

Recommendations

- The personnel responsible for receiving the unit must conduct a visual inspection in order to identify all damage to which the unit may have been subjected during transport: refrigerating circuit, electrical cabinet, chassis and cabinet.
- During installation, troubleshooting and maintenance operations, never use the pipes as a step: under the stress, the pipes may break and the refrigerant may cause serious burns.

For safe installation and trouble-free operation, you must:

- Carefully read this instruction booklet before beginning.
- Follow each installation or repair step exactly as shown.
- Observe all local, state and national electrical (and safety) codes.
- Pay close attention to all warning and caution notices given in this manual.
- Supply the unit with a dedicated electrical line.
- Make install the unit by qualified personnel, in possession of license F-GAS.
- Before installation, check that the voltage of the electric supply in your home or office is the same as the voltage shown on the nameplate.
- Always leave the unit powered. The system contains safety devices that must be activated, especially during the winter period.

**WARNING**

This symbol refers to a hazard or unsafe practice which can result in severe personal injury or death.

**CAUTION**

This symbol refers to a hazard or unsafe practice which can result in personal injury or product or property damage.

If necessary, get help

These instructions are all you need for most installation sites and maintenance conditions.

If you require help for a special problem, contact our sale/service outlet or your certified dealer for additional instructions.

In case of improper installation

The manufacturer shall in no way be responsible for improper installation or maintenance service, including failure to follow the instructions in this document.

SPECIAL PRECAUTIONS

- During installation, connect before the hydraulic and refrigerant system and then the wiring one; proceed in the reverse order when removing the unit.

**WARNING****When wiring**

ELECTRICAL SHOCK CAN CAUSE SEVERE PERSONAL INJURY OR DEATH.

ONLY QUALIFIED, EXPERIENCED ELECTRICIANS SHOULD ATTEMPT TO WIRE THIS SYSTEM.

- Do not supply power to the unit until all wiring and tubing are completed or reconnected and checked, to ensure the grounding.
- Highly dangerous electrical voltages are used in this system. Carefully refer to the wiring diagram and these instructions when wiring.
Improper connections and inadequate grounding can cause accidental injury and death.
- **Ground the unit** following local electrical codes.
- The Yellow/Green wire cannot be used for any connection different from the ground connection.
- Connect all wiring tightly. Loose wiring may cause overheating at connection points and a possible fire hazard.
- Do not allow wiring to touch the refrigerant tubing, compressor, or any moving parts of the fan.
- Do not use multicore cable when wiring the power supply and control lines. Use separate cables for each type of line.

When transporting

Be careful when picking up and moving the unit. Get a partner to help, and bend your knees when lifting to reduce strain on your back. Sharp edges or thin aluminium fins on the unit can cut your fingers.

When installing**... In a wall or floor**

Make sure they are strong enough to hold the unit weight. It may be necessary to build a strong wooden or metal frame to provide added support.

... In moist or uneven locations

Use a raised concrete base to provide a solid level foundation for the unit.

This prevents damage and abnormal vibrations.

... In area with strong winds

Securely anchor the unit down with bolts and a metal frame. Provide a suitable air baffle.

... In a snowy area

Install the unit on a raised platform that is higher than drifting snow. Provide snow vents.

When connecting refrigerant tubing of Emix / Emix-Tank

- Keep all tubing runs as short as possible (max. 10m).
- Use the flare method for connecting tubing.
- Apply refrigerant lubricant to the matching surfaces of the flare and union tubes before connecting them; screw by hand and then tighten the nut with a torque wrench for a leak-free connection.
- Check carefully for leaks before starting.
- Insulate the tubes with foamed polyethylene (min. thickness 8mm).

When connecting hydraulic tubing

- Keep all tubing runs as short as possible.
- Insulate the tubing.
- Check carefully for leaks before starting.

When servicing

- Turn the power OFF at the main power board before opening the unit to check or repair electrical parts and wiring.
- Keep your fingers and clothing away from any moving parts.
- Clean up the site after the work, remembering to check that no metal scraps or bits of wiring have been left inside the unit being serviced.
- Ventilate the room during the installation or testing the refrigeration system; make sure that, after the installation, no gas leaks are present, because this could produce toxic gas and dangerous if in contact with flames or heat-sources.

1 - INSTALLATION LOCATION

AVOID

- Heat sources, exhaust fans.
- Direct sunlight.
- Damp, humid or uneven locations.
- Locations where salty sea water can splash directly onto the unit or sulphurous air near a spa.
- Areas where there is strong wind blowing against the unit's air exhaust.
- To make holes in areas where electrical wiring or conduits are located.
- To place the unit's air exhaust directed towards surrounding windows.
- That vibrations and noise are transmitted to a nearby building.

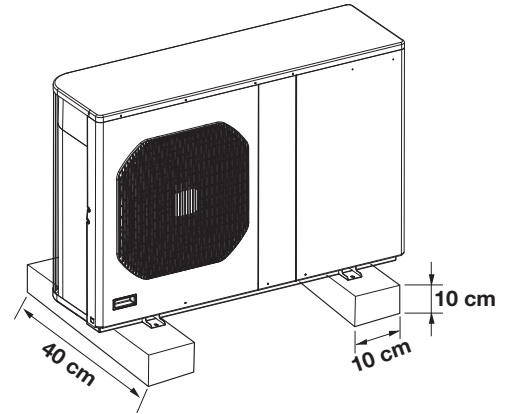

DO

- Choose places as cool as possible and well ventilated.
- Use lug bolts or equal to bolt down the unit, reducing vibration and noise.

IMPORTANT

- Provide a solid base for the unit, raised from the ground level. Fix the unit to base using 4 anchor bolts. (See figure). Utilise the 4 adhesive dampers supplied with the unit.
- Leave a minimum operation and maintenance area around the unit. (See figure).

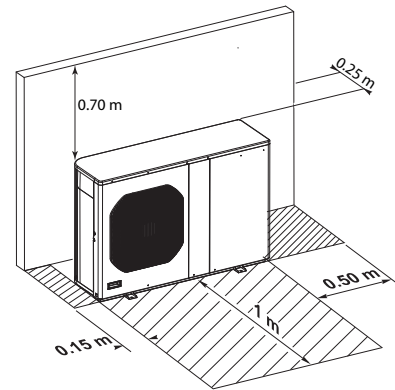

OPERATING CONDITIONS

Water system pressure

Minimum: 1,5 bar

Maximum: 2,0 bar

Water temperature

The maximum allowable water inlet temperature of the heat pump is 75 °C

Water volume of the system (to be compulsorily checked)

Minimum: **AIM06:** 40 litres (*) **AIM11:** 80 litres (*)

AIM08: 40 litres (*) **AIM14:** 80 litres (*)

Maximum: dimension the expansion vessel according to the maximum volume of water, the maximum water temperature and the plant static height.

(*) If the water volume of the system (plant and product) is below the minimum, a buffer tank must be installed. For the minimum water volume, consider the volume continuously connected to the heat pump (don't consider the volumes which could be isolated by automatic valves).

Operating limits

Outdoor ambient temperature

Heating: -20°C / +35°C

Cooling: +10°C / +47°C

Maximum temperature of water outlet

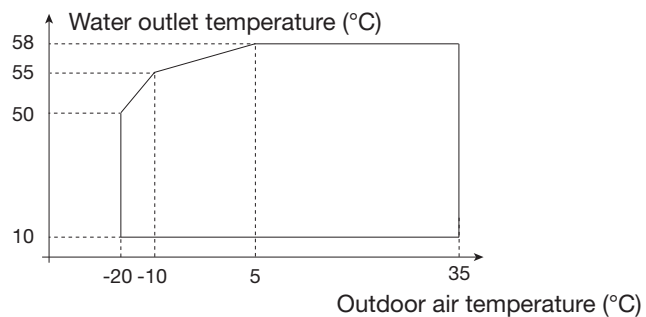

TUBING LENGTH OF EMIX / EMIX-TANK AND ELEVATION DIFFERENCE LIMITS

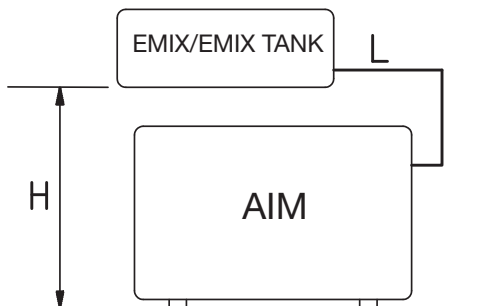

L = MAXIMUM TUBING LENGTH 10 m

REQUIRED AMOUNT OF ADDITIONAL REFRIGERANT
For tubing Emix (3/8") = 15g/m

H = LIMIT OF ELEVATION DIFFERENCE BETWEEN THE UNITS: 10 m

ACCESSORIES SUPPLIED WITH THE UNIT

1. RUBBER COVER (AIM06)
CONICAL COVER (AIM08-11-14)
2. DRAIN TUBE
3. ADHESIVE DAMPER (4 pcs)
4. OUTSIDE TEMPERATURE SENSOR

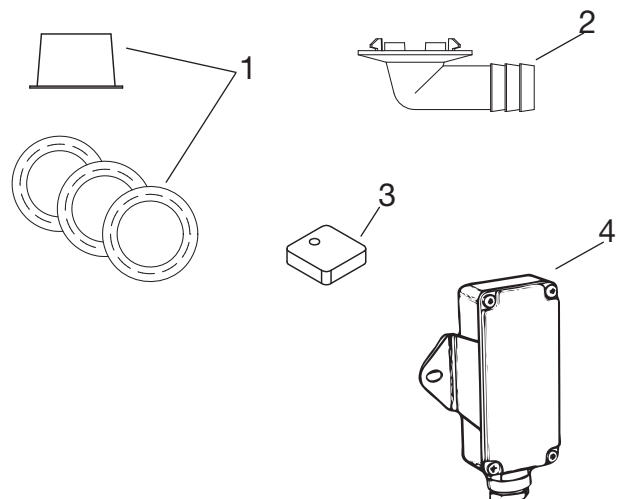

DIMENSIONS AND WEIGHT

Model	Weight (kg)
AIM06EMX	64
AIM08EMX	73
AIM11EMX	92
AIM11EMX3PH	95
AIM14EMX	145
AIM14EMX3PH	145

		AIM06	AIM08	AIM11	AIM14
1	Water inlet connection (male)	3/4"	3/4"	1"	1"
2	Water outlet connection (male)	3/4"	3/4"	1"	1"
3	Water circuit fill / drain (male)	1/2"	1/2"	1/2"	1/2"
4	Holes for electric cables	-	-	-	-
5	Emix tubes' connection (inlet / outlet)	3/8"	3/8"	3/8"	1/2"

AIM06

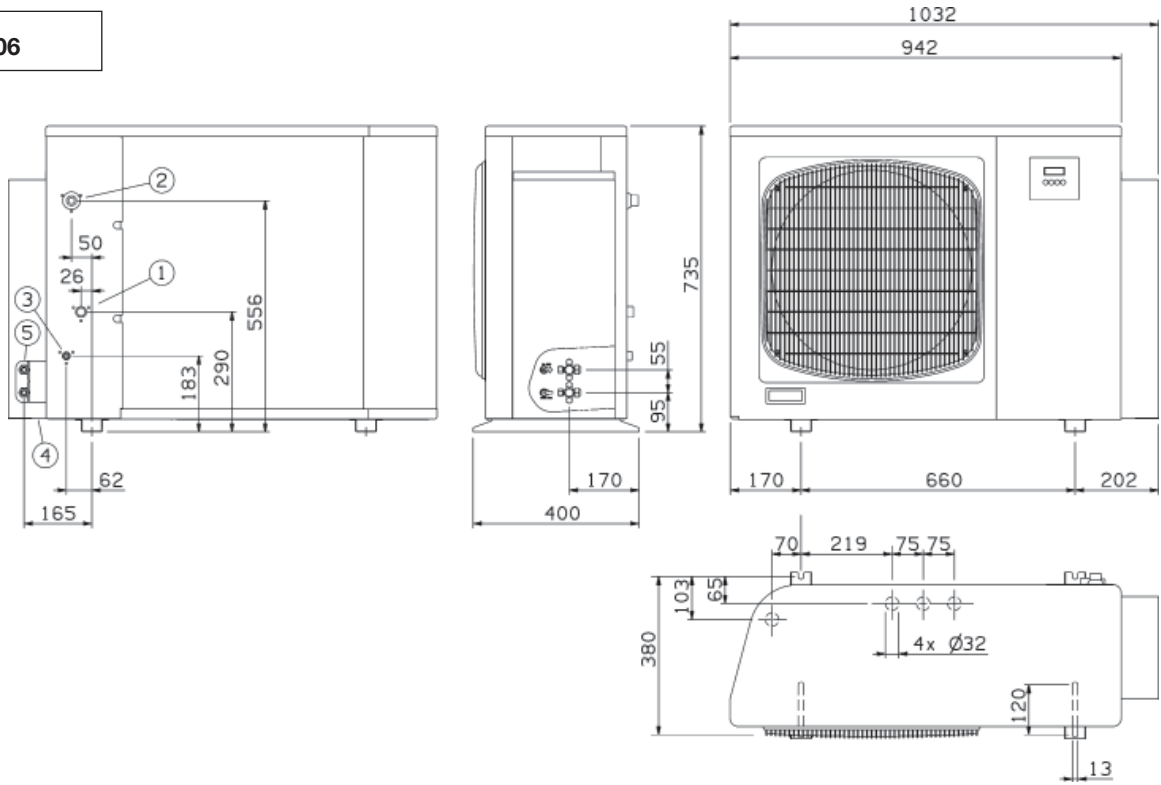

AIM08

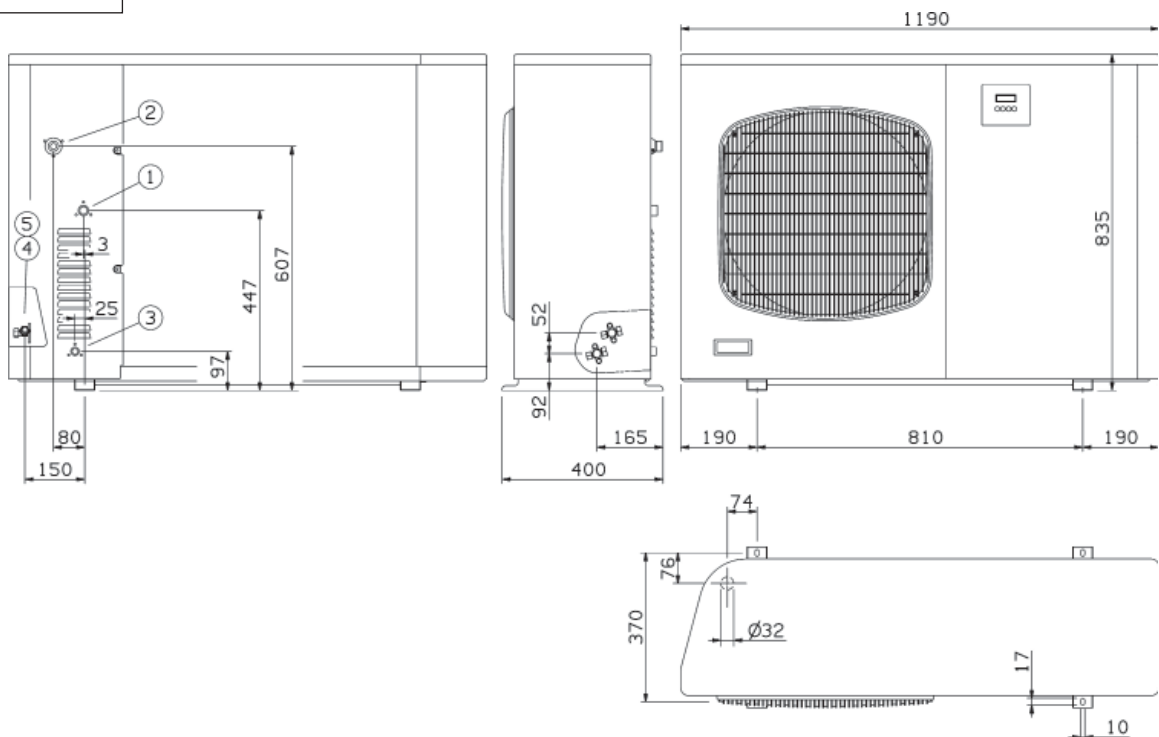

AIM11

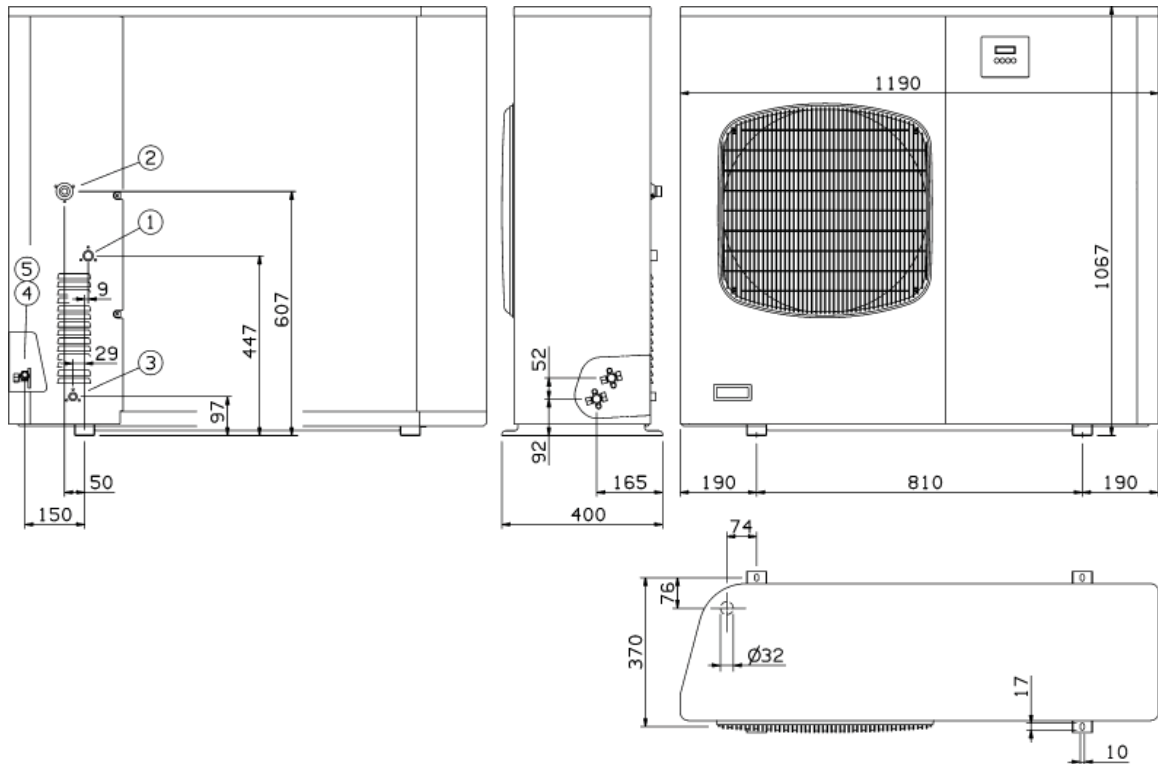

AIM14

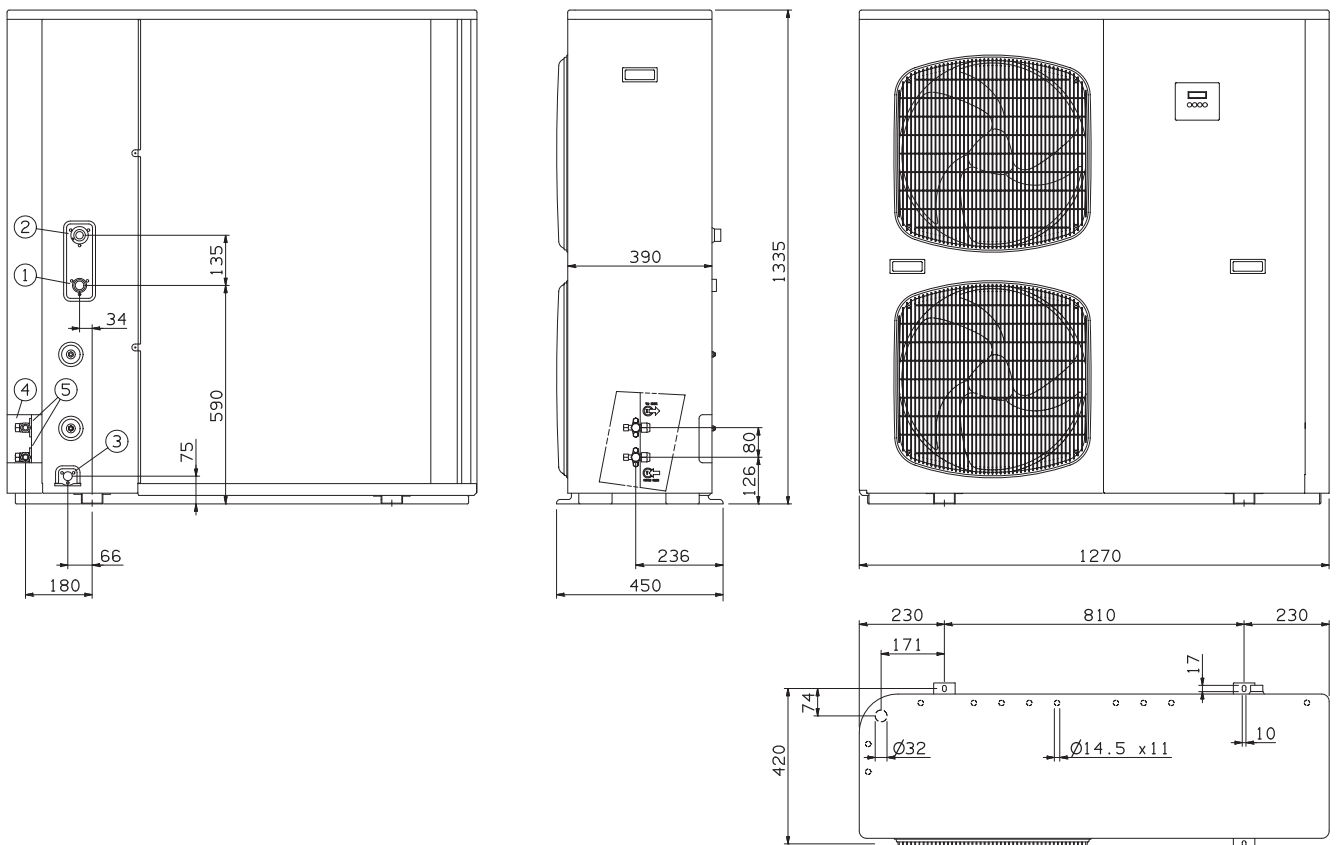

ADDITIONAL MATERIAL REQUIRED FOR INSTALLATION (NOT SUPPLIED)

- Deoxidized annealed copper tube for refrigerant tubing connecting Emix; it has to be insulated with foamed polyethylene (min. thickness 8mm).

TUBING	
OUTER DIAMETER	MIN. THICKNESS
9,52 mm (3/8")	0,8 mm

- PVC pipe for condensate drain pipe (ø int.18mm) in length suitable to let the condensate flow into the outside drainage.
- Anti-freeze oil for flare connections (about 30g.)
- Electric wire: use insulated copper wires of size and length as shown at paragraph "SYSTEM WIRING DIAGRAMS".
- Tubes for water.

Tools required for installation (not supplied)

- | | | |
|------------------------------|-----------------------|----------------------------|
| 1. Standard screwdriver | 7. Hacksaw | 13. Torque wrench |
| 2. Phillips head screwdriver | 8. Core bits ø 5 | 14. Adjustable wrench |
| 3. Knife or wire stripper | 9. Hammer | 15. Reamer (for reburring) |
| 4. Tape measure | 10. Drill | 16. Hex. key |
| 5. Level | 11. Tube cutter | |
| 6. Sabre saw or key hole saw | 12. Tube flaring tool | |

3 - CONNECTIONS

HYDRAULIC CONNECTION

- Connect the water pipes to the corresponding connections:
 - For diameters and position (see page 6).
- It is mandatory to install a hydraulic filter (not supplied) on the water intake. Connect it using 2 isolation valves (not supplied) for cleaning purposes.
- Install a shut-off valve (not supplied) if a fill / drainage connection is used.
- It is recommended to install anti-vibration flexible hoses (not supplied), for the hydraulic connections.
- It is recommended to install an automatic vent valve at the water outlet.

HYDRAULIC CONNECTION WITH DHW KIT

- Keep all tubing runs as short as possible (recommended length: 3m).
- Utilise isolated tubes: 25mm (inner ø) 32mm (outer ø).

REFRIGERANT CONNECTION WITH EMIX / EMIX TANK

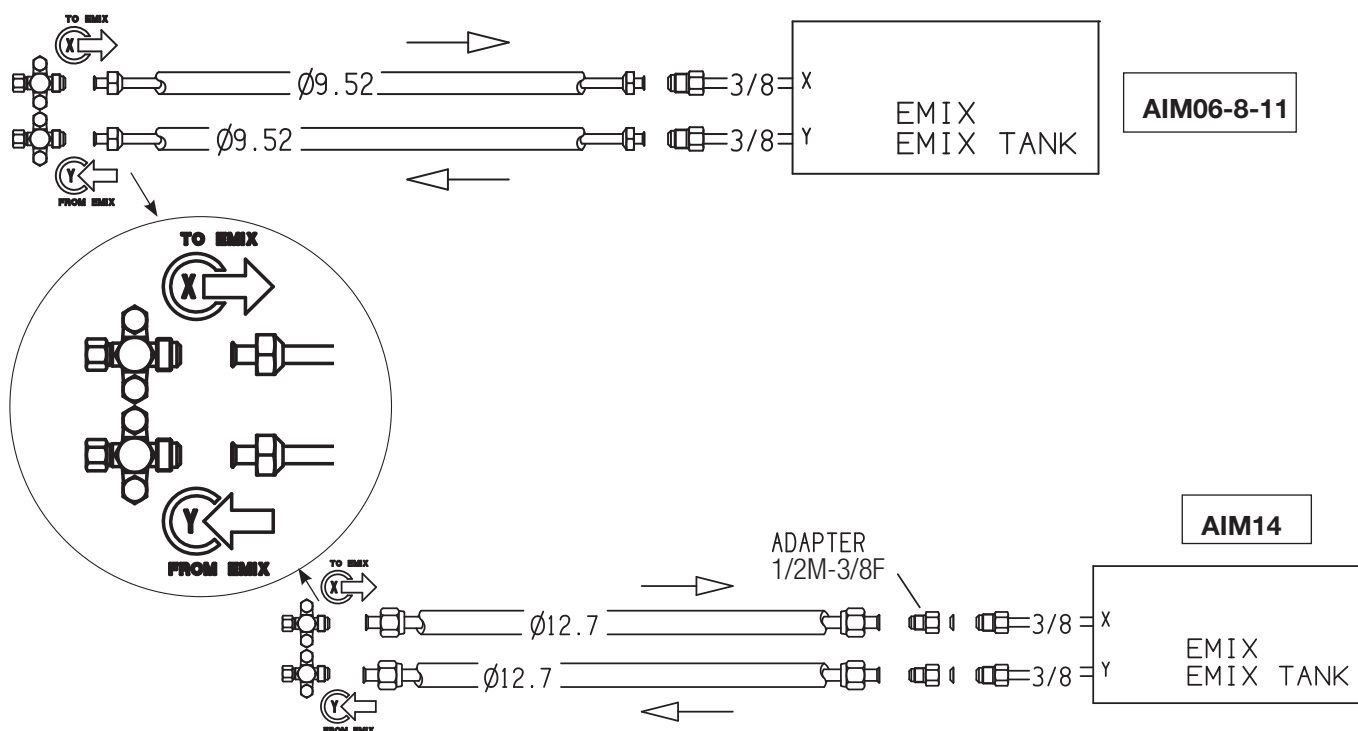

ELECTRICAL CONNECTION

Remove the cover to access the terminal blocks, then connect the power line and interconnecting wires to the unit on the terminal strip and secure them with clamps.

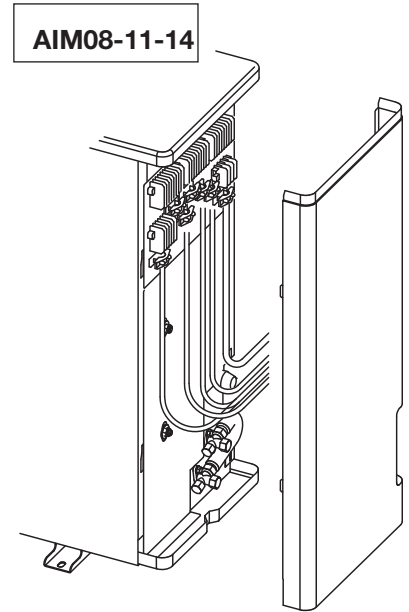
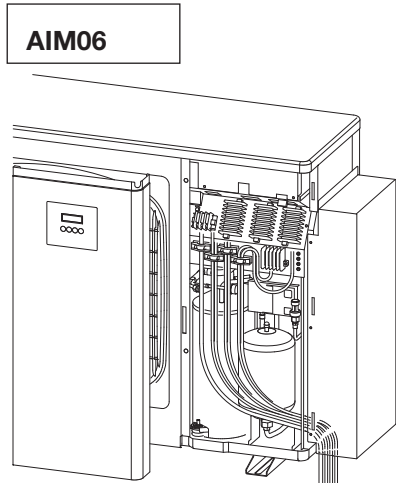

NOTE: Attention!
The panel is connected with a wire to the electrical junction box. Be careful not to pull the cable or disconnect it.

EMX MODELS

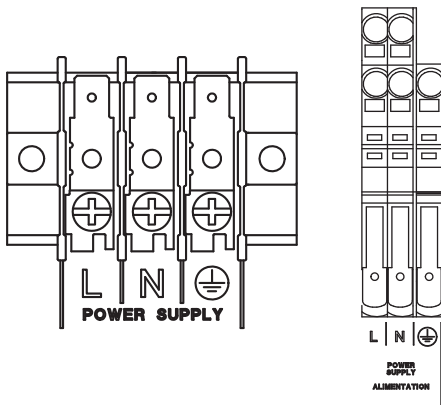

EMX3PH MODELS

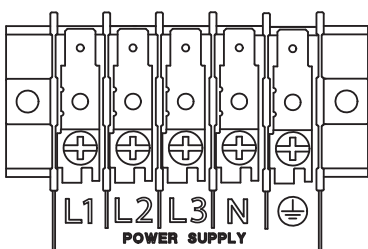

TERMINAL BLOCKS

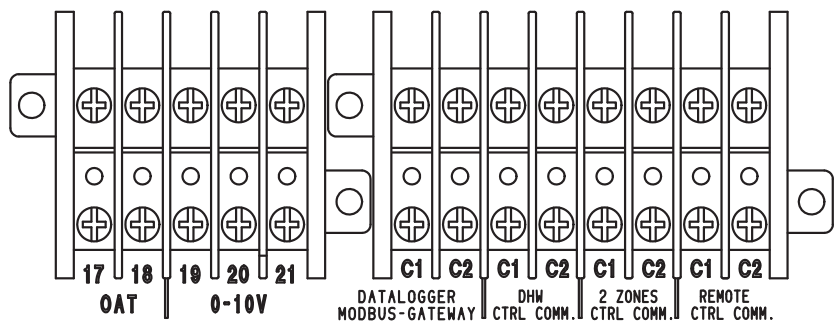
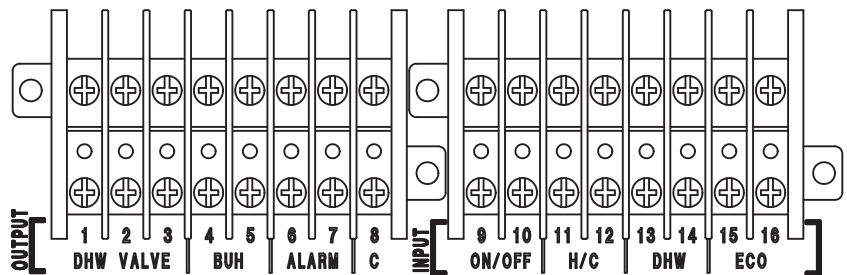

CONDENSATE DRAIN CONNECTION

Use the supplied accessories, connecting the drain tube to one of the holes of the basement; close the remaining holes with the covers (see section ACCESSORIES SUPPLIED WITH THE UNIT).

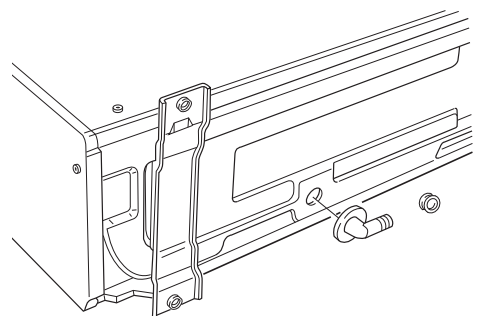

4 - SYSTEM WIRING DIAGRAMS

LENGTH, SIZE WIRES AND DELAYED FUSE

MODEL	A	B	C	D	Max. electric input kW / A	
	S (mm ²)	S (mm ²)	S (mm ²)	S (mm ²)		
AIM06EMX	2,5	0,75	0,75	0,75	2,8 / 12,7	16 A
AIM08EMX	2,5	0,75	0,75	0,75	3,5 / 15,9	20 A
AIM11EMX	4	0,75	0,75	0,75	4,2 / 19,1	25 A
AIM11EMX3PH	1,5	0,75	0,75	0,75	4,2 / 8,0	10 A
AIM14EMX	4	0,75	0,75	0,75	5,2 / 23,8	30 A
AIM14EMX3PH	1,5	0,75	0,75	0,75	5,2 / 10,0	12,5 A

Supply power wire A:

Multipolar electric wire; the size of the suggested electric wire is shown on table. The wire must be Mod. H07RN-F (according to CEI 20-19 CENELEC HD 22). Make sure the length of the conductors between the fixing point and the terminals allows the straining of the conductors L, N before that of the grounding.

Connecting wire B (SHIELDED):

Bipolar electric shielded wire; the size of the suggested electric wire is shown on table. The wires have not to be lighter than Mod. H05VVC4V5-K (according to CEI 20-20 CENELEC HD21).

Connecting wire C / D:

Multipolar electric wire; the size of the suggested electric wire is shown on table. The wires have not to be lighter than Mod. H07RN-F (wire C) / H05RN-F (wire D), according to CEI 20-19 CENELEC HD22).

WIRING DIAGRAMS' SYMBOLS

 DELAYED FUSE

220 - 240 V / 1 / 50 Hz



380 - 415V / 3N / 50 Hz

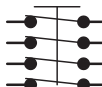

Main switch for disconnection from the supply line must have a contact separation in all poles that provides full disconnection under category III overvoltage conditions.

4.1 - FULL CONFIGURATION

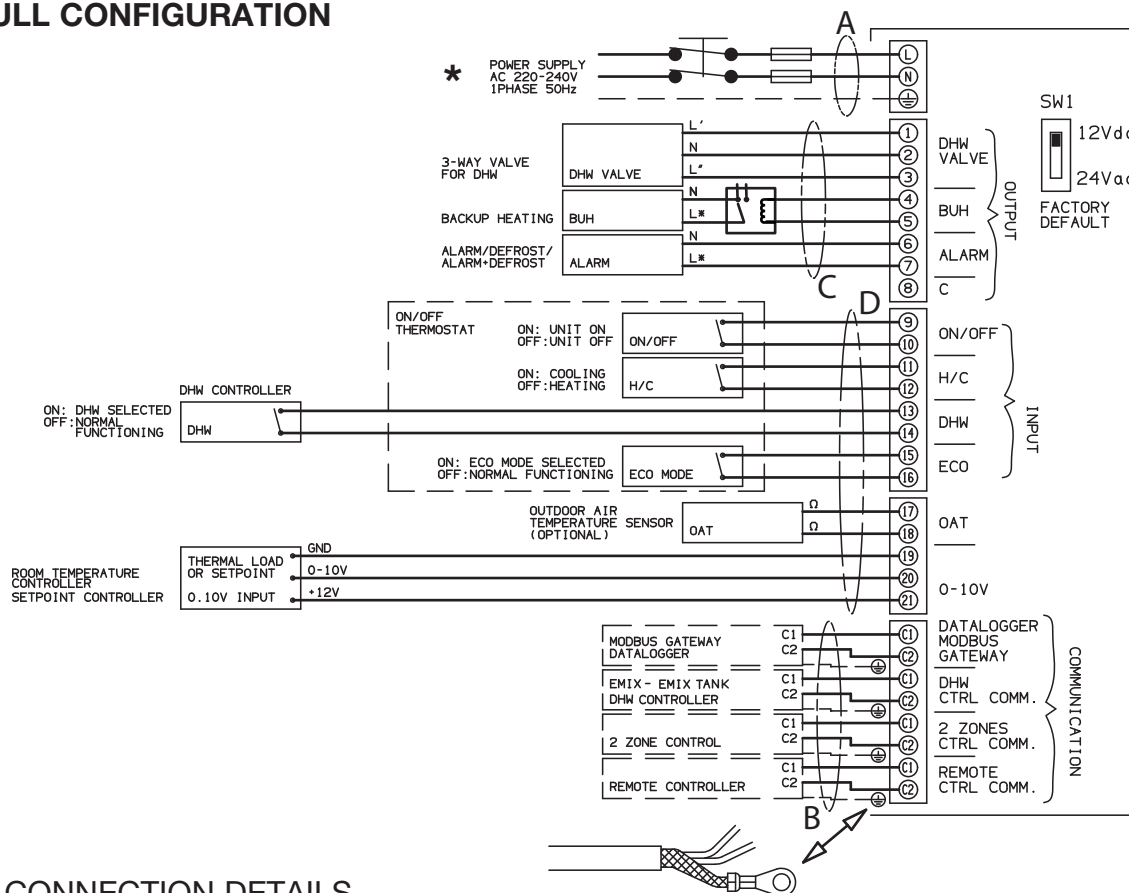

* SEE CONNECTION DETAILS

4.2 - CONNECTIONS DETAILS

• POWER SUPPLY

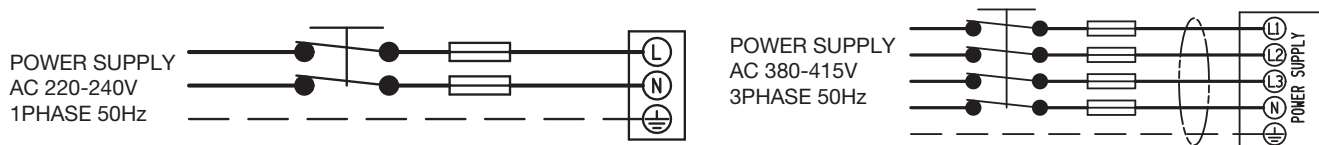

• DHW VALVE

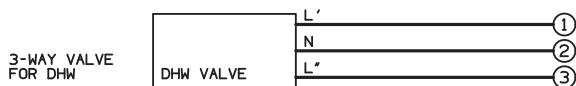

- (1): DHW valve closing command. Phase output 230 Vac / 20 W max.
- (2): Neutral
- (3): DHW valve opening command. Phase output 230 Vac / 20 W max.

• BACKUP HEATING

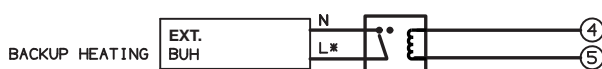

- (4): Neutral
- (5): Backup heating activation command. Phase output 230 Vac / 20 W max.

It is necessary to insert an external backup heating pilot relay (boiler, resistance, etc.).

• ALARM / DEFROST

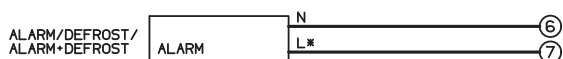

- (6): Neutral
- (7): Alarm / defrost signaling. Phase output 230 Vac / 20 W max.

• THERMOSTAT ON/OFF



- If switch SW1 (see page 26) of I/O board is set on 12 Vdc, connect thermostat dry contact between poles (9) and (10):

- (9): Low voltage input
- (10): 12 Vdc

Closed contact: heating / cooling request

Open contact: unit in standby

- If switch SW1 (see page 26) of I/O board is set on 24 Vac, connect neutral of power supply 24 Vac to terminal (8) and output 24 Vac of thermostat to terminal (9):

- (8): Neutral 24 Vac
- (9): Phase input 24 Vac
- (10): Not connected

Powered input: heating / cooling request

Not powered input: unit in standby

NOTE: On the terminals (9) and (10) a jumper is preinstalled (factory default). Remove the jumper before connecting the thermostat.

• THERMOSTAT H/C



- If switch SW1 (see page 26) of I/O board is set on 12 Vdc, connect thermostat dry contact between poles (11) and (12):

(11): Low voltage input

(12): 12 Vdc

Closed contact: cooling mode selected

Open contact: heating mode selected

- If switch SW1 (see page 26) of I/O board is set on 24 Vac, connect neutral of power supply 24 Vac to terminal (8) and output 24 Vac of thermostat to terminal (11):

(8): Neutral 24 Vac

(11): Phase input 24 Vac

(12): Not connected

Powered input: cooling mode selected

Not powered input: heating mode selected

• DHW CONTROLLER

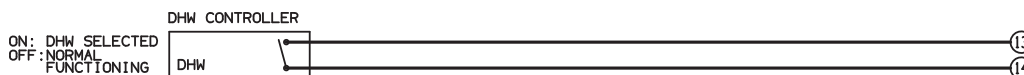

- If switch SW1 (see page 26) of I/O board is set on 12 Vdc, connect thermostat dry contact between poles (13) and (14):

(13): Low voltage input

(14): 12 Vdc

Closed contact: ACS production request / secondary setpoint selection

Open contact: normal mode

- If switch SW1 (see page 26) of I/O board is set on 24 Vac, connect neutral of power supply 24 Vac to terminal (8) and output 24 Vac of thermostat to terminal (13):

(8): Neutral 24 Vac

(13): Phase input 24 Vac

(14): Not connected

Powered input: ACS production request / secondary setpoint selection

Not powered input: normal mode

• **ECO MODE**

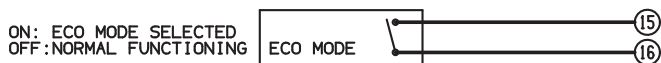

- If switch SW1 (see page 26) of I/O board is set on 12 Vdc, connect thermostat dry contact between poles (15) and (16):

(15): Low voltage input
 (16): 12 Vdc

Closed contact: ECO mode selection (limitation of maximum power consumption)

Open contact: normal mode

- If switch SW1 (see page 26) of I/O board is set on 24 Vac, connect neutral of power supply 24 Vac to terminal (8) and output 24 Vac of thermostat to terminal (15):

(8): Neutral 24 Vac
 (15): Phase input 24 Vac
 (16): Not connected

Powered input: ECO mode selection (limitation of maximum power consumption)

Not powered input: normal mode

• **OUTDOOR TEMPERATURE SENSOR (OAT)**



INSTALLATION OF THE OUTDOOR TEMPERATURE SENSOR FOR HEAT PUMP OPERATION

This sensor must be located outside in a location that is representative of the temperature to be measured (on a wall facing North / North-west) and located away from parasitic heat sources (chimney, thermal bridge, etc..) and sheltered from inclement weather (under a roof overhand, for example).

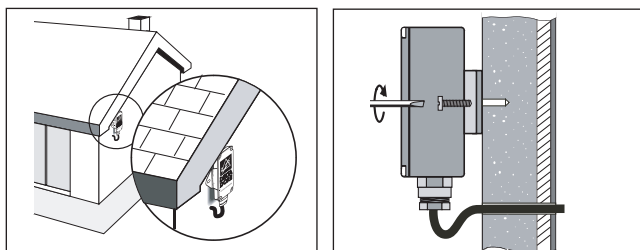

NOTE: The installation of this sensor is optional.

• **ROOM TEMPERATURE CONTROLLER / SETPOINT CONTROLLER**

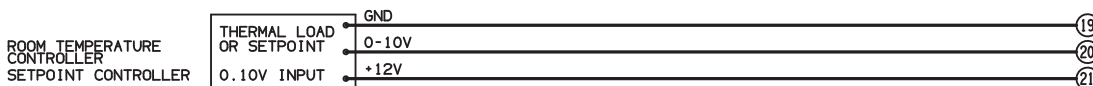

(19): Low voltage ground
 (20): Input 0-10 Vdc
 (21): 12 Vdc

• DATALOGGER / MODBUS GATEWAY / EMIX / 2 ZONE CONTROL / REMOTE CONTROLLER

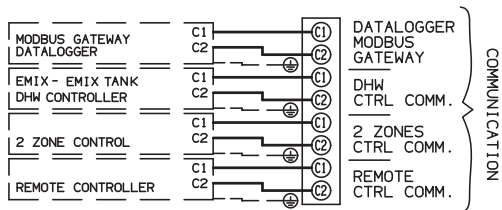

Connect terminals (C1) and (C2) to the corresponding terminals (C1) and (C2) of the connected unit (Emix, Remote display, etc...).

Connect the shield of the communication wire to the corresponding ground wire.

4.3 - CONNECTION EXAMPLES

EMIX / EMIX TANK CONNECTION

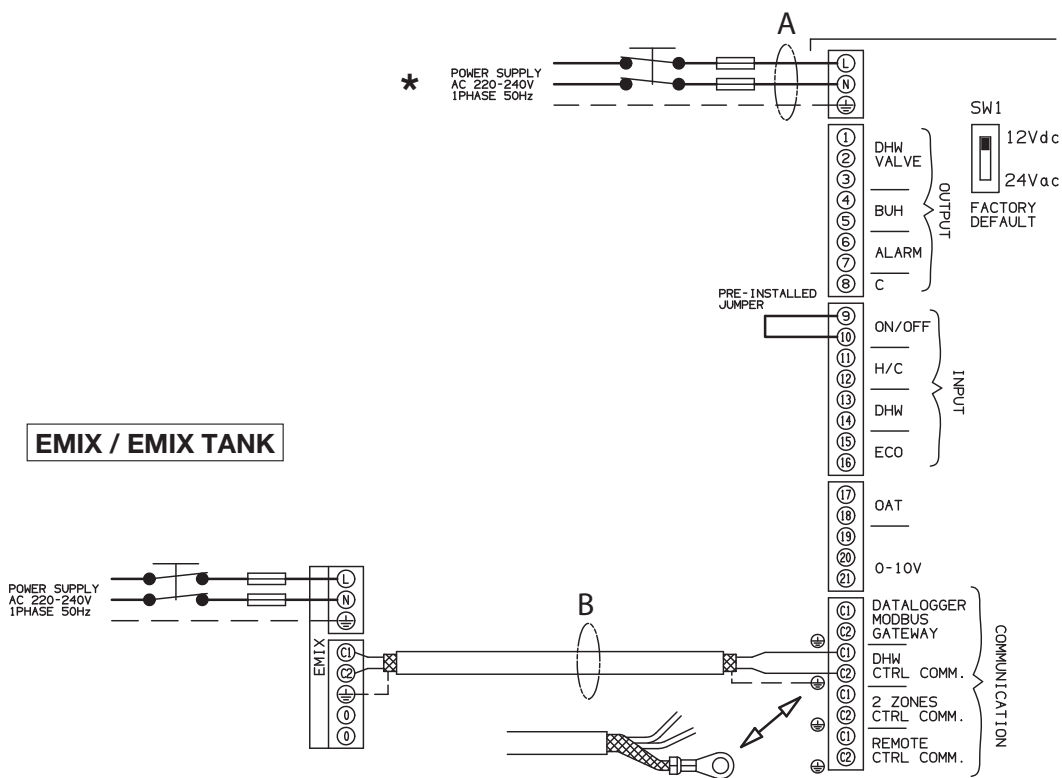

* SEE CONNECTION DETAILS

WORKING MODE SELECTION WITH ON/OFF THERMOSTAT

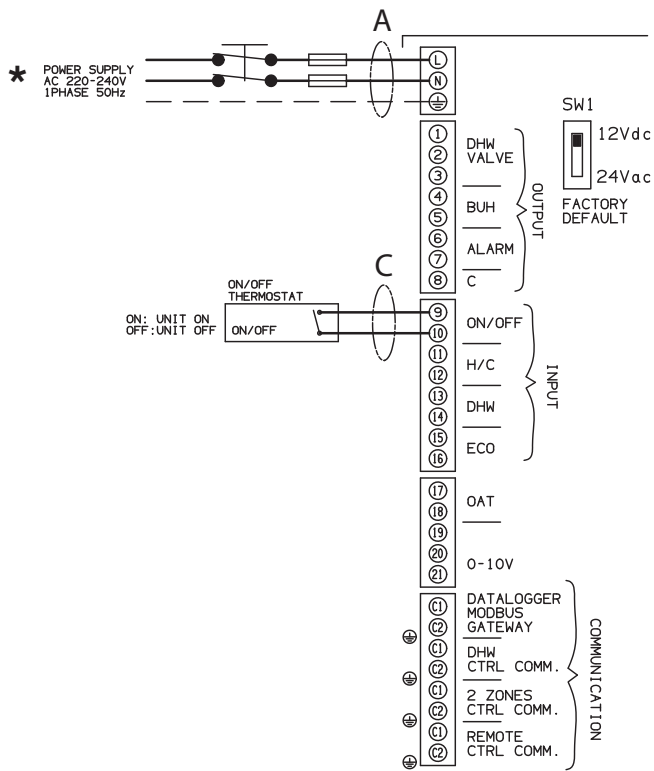

WORKING MODE SELECTION WITH ON/OFF THERMOSTAT AND HEAT/COOLING (H/C)

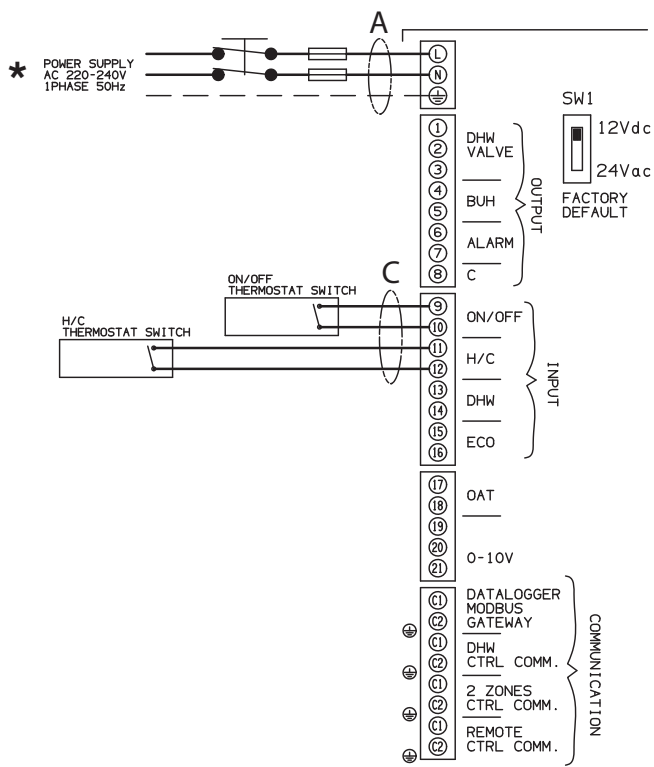

NOTE: see paragraph “STARTING” section “JUMPERS/SWITCH SETTING” - ENABLING COOLING MODE

*** SEE CONNECTION DETAILS**

WORKING MODE SELECTION WITH ON/OFF THERMOSTAT AND ECO FUNCTION

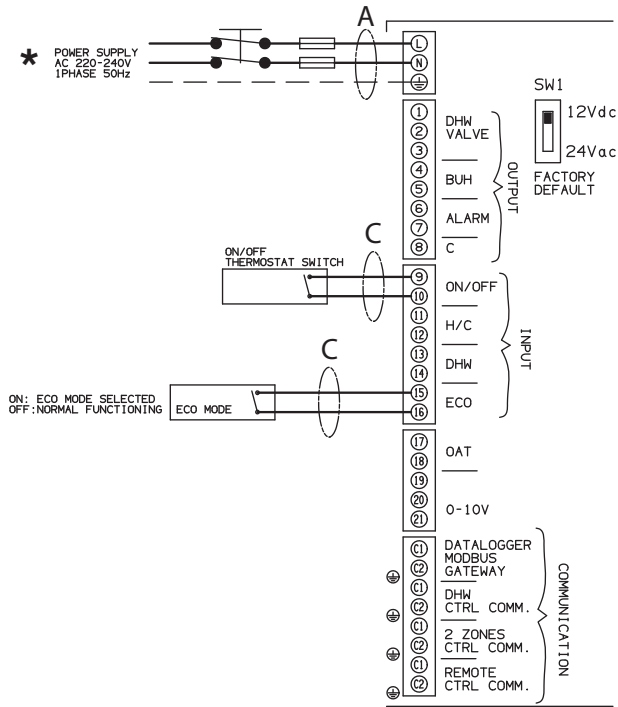

WORKING MODE SELECTION WITH ON/OFF THERMOSTAT, THERMOSTAT FOR DHW AND SAFETY THERMOSTAT

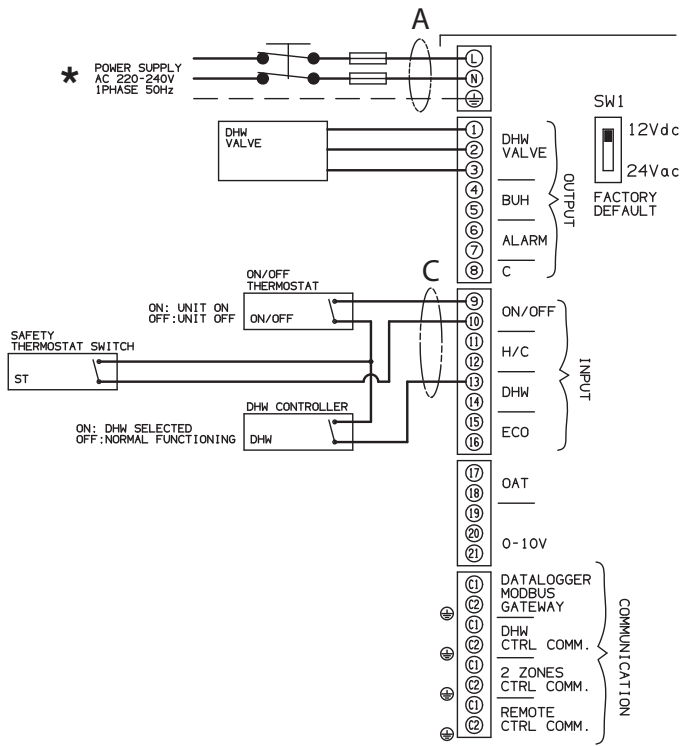

* SEE CONNECTION DETAILS

WORKING MODE SELECTION WITHOUT THERMOSTAT

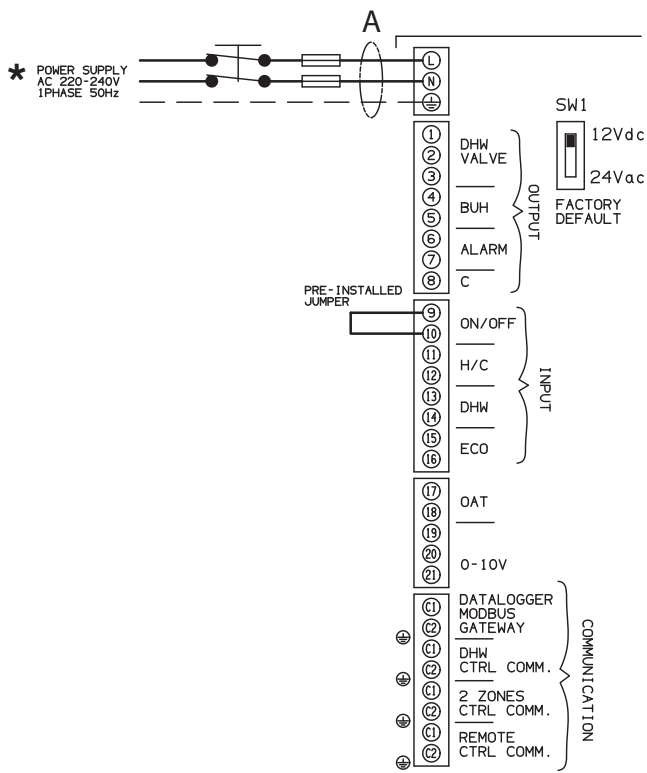

WORKING MODE SELECTION WITHOUT THERMOSTAT + SAFETY SWITCH

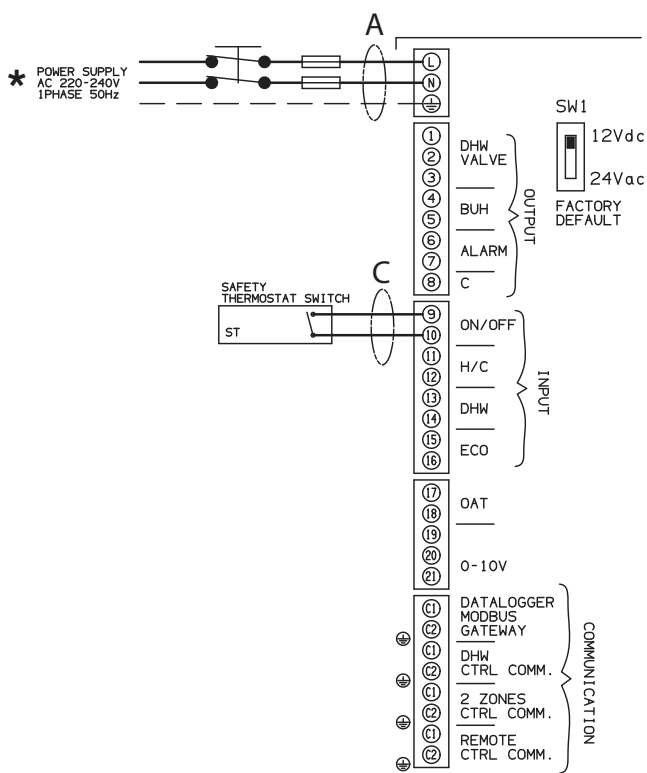

* SEE CONNECTION DETAILS

WORKING MODE SELECTION WITH 0 - 10V ROOM TEMPERATURE CONTROLLER AND DHW PRODUCTION

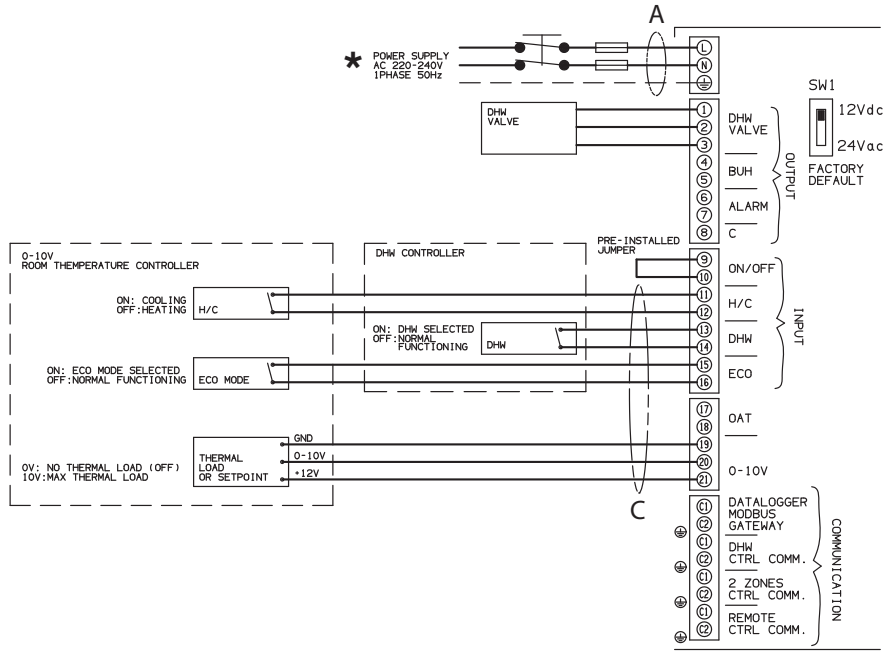

WORKING MODE SELECTION WITH 24 Vac THERMOSTAT AND DHW PRODUCTION

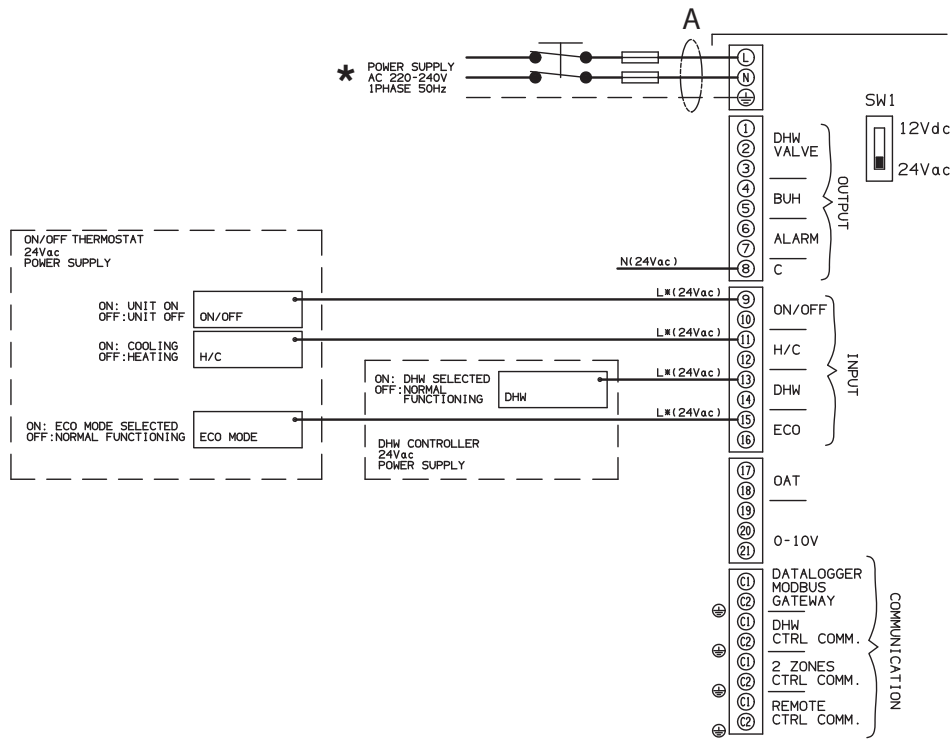

* SEE CONNECTION DETAILS

5 - EMIX / EMIX TANK INSTALLATION

EN

- A** Use insulated copper tube. Cut approximate 30-50 cm. longer than actual distance between units.

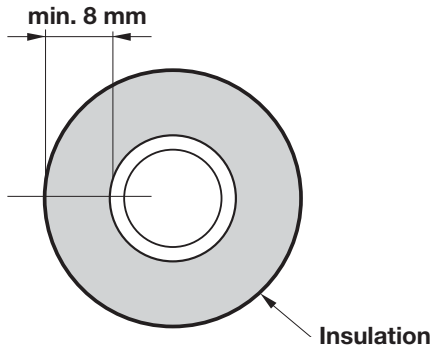

- B** Remove burrs at the ends of the copper tubes. Hold the tube end downward and be sure that no dirt falls into the tube.

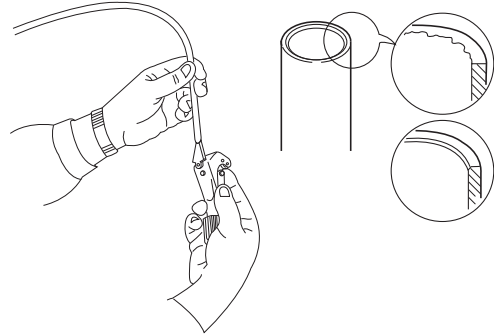

- C** Make a flare at the end of copper tubes.

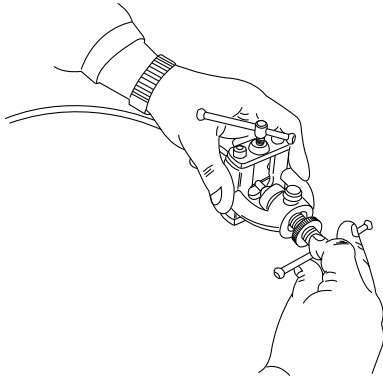

- D** A good flare has the following characteristics:

- inside surface is glossy and smooth
- edge is smooth
- tapered sides are of uniform length.

Apply refrigerant lubricant to the matching surface of the flare and union before connecting them together.

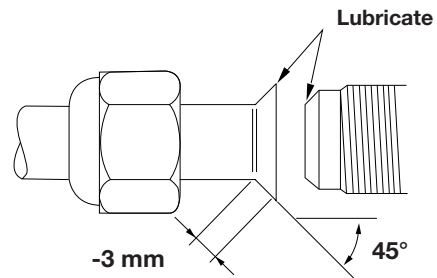

- E** Tighten connections using a spanner and a torque wrench; apply specified torque (see table).

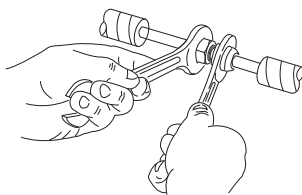

- F** Insulate tubes leaving connections uncovered for leak test.

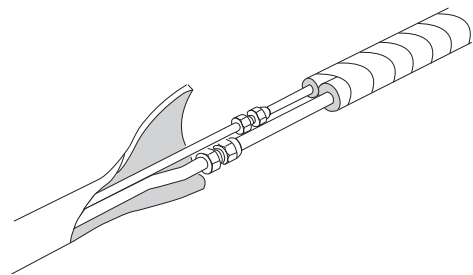

TUBE DIA.	TIGHTENING TORQUE
9,52 mm (3/8")	Approx. 350 – 400 kgcm (30 - 40 Nm)

G Air purging of Emix/Emix tank unit and refrigerant tubes

Close both valves, recover the refrigerant inside the bypass using a refrigerant recovery. Remove the bypass and connect Emix / Emix tank unit (See Installation Manual). Connect the vacuum pump to the unit as shown in the figure. Air and moisture have harmful effects on the refrigerant system. Then start vacuum pump and let it run for the time indicated in the table (vacuum 10 mm Hg abs.).

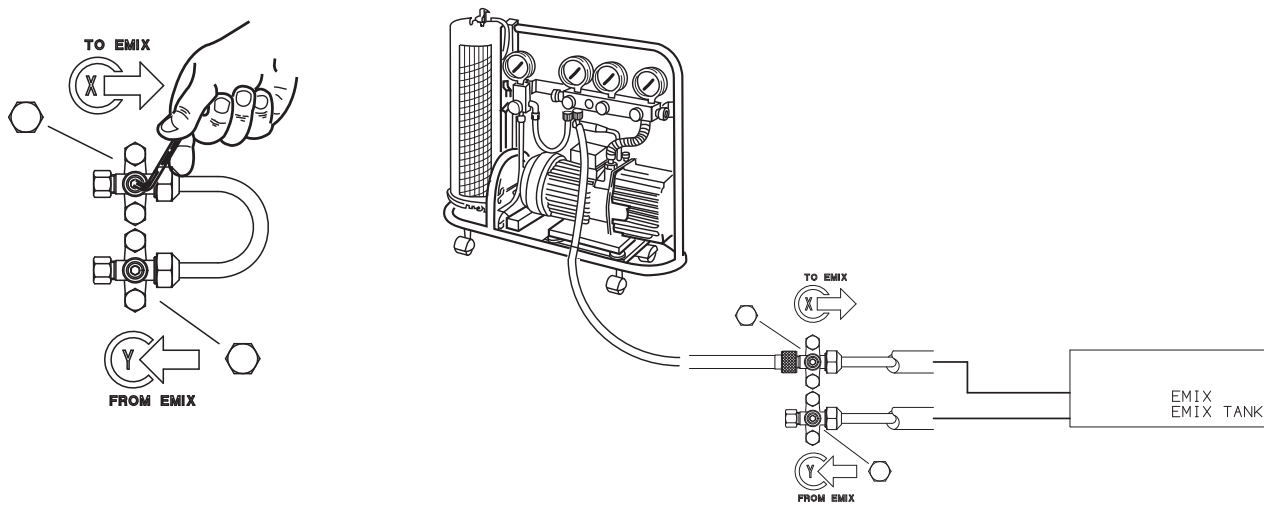

VACUUM PUMP CAPACITY 100 l /h	
Tubing length: less than 10 m	Tubing length: longer than 10 m
10 min. or more	15 min. or more

H With vacuum pump still running close the low pressure knob on valve manifold. Then stop vacuum pump. Using an hexagonal key, open the service valve, then close it after 10 seconds. Check tightness of all joints using liquid soap. Turn the service valves stem in counterclockwise to fully open the valves. At this point vacuum pump flexible hose can be disconnected.

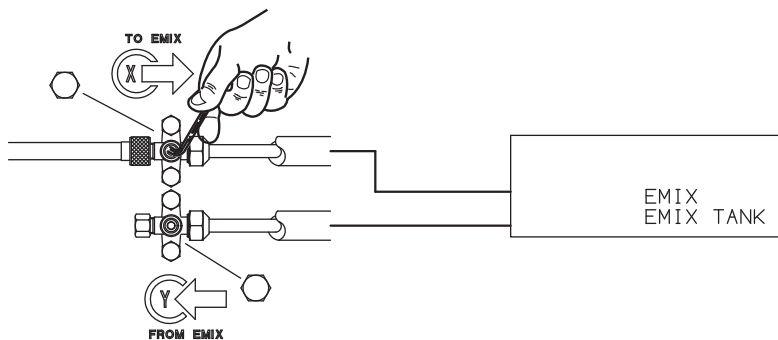

BASIC FUNCTIONS OF THE SERVICE VALVES

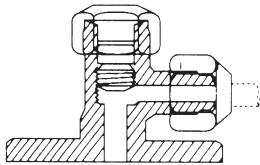
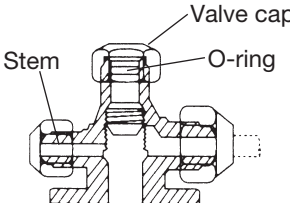
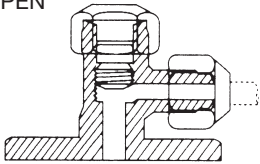
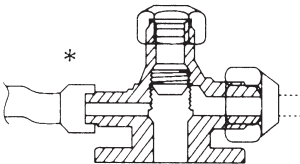
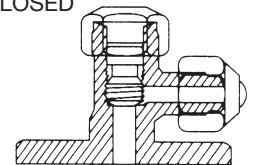
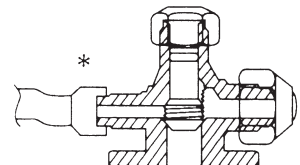
Action	Service valve (2-way)	Service valve (3-way)
Shipping, operating and test running the unit	<p>OPEN</p> 	
Measuring pressure and gas charging	<p>OPEN</p> 	
Air purging with a vacuum pump	<p>CLOSED</p> 	

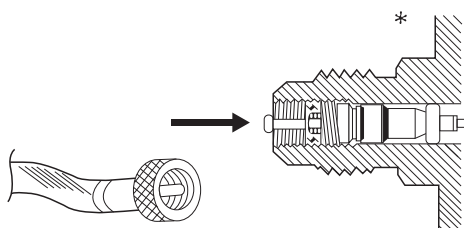

The service port on the unit service valve uses a Schrader core valve to access the refrigerant system. Therefore, be sure to use a hose connector which has a push-pin inside.

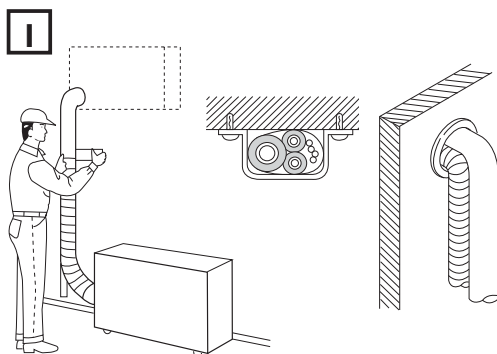

Complete insulation of refrigerant tubes; wrap with armoning tape. Fix and support tubes with brackets. Seal hole in the wall, if necessary.

NOTE

In case the unit is to be moved or before servicing the refrigerant circuit, see the procedure in the Installation Manual of Emix/Emix tank (HOW TO DISCONNECT AND REMOVE EMIX UNIT/EMIX TANK UNIT).

6 - SYSTEM LAYOUT

**ONLY HEATING, SINGLE ZONE.
DHW PRODUCTION WITH EMIX TANK AND BACKUP HEATING WITH THERMAL SOLAR.**

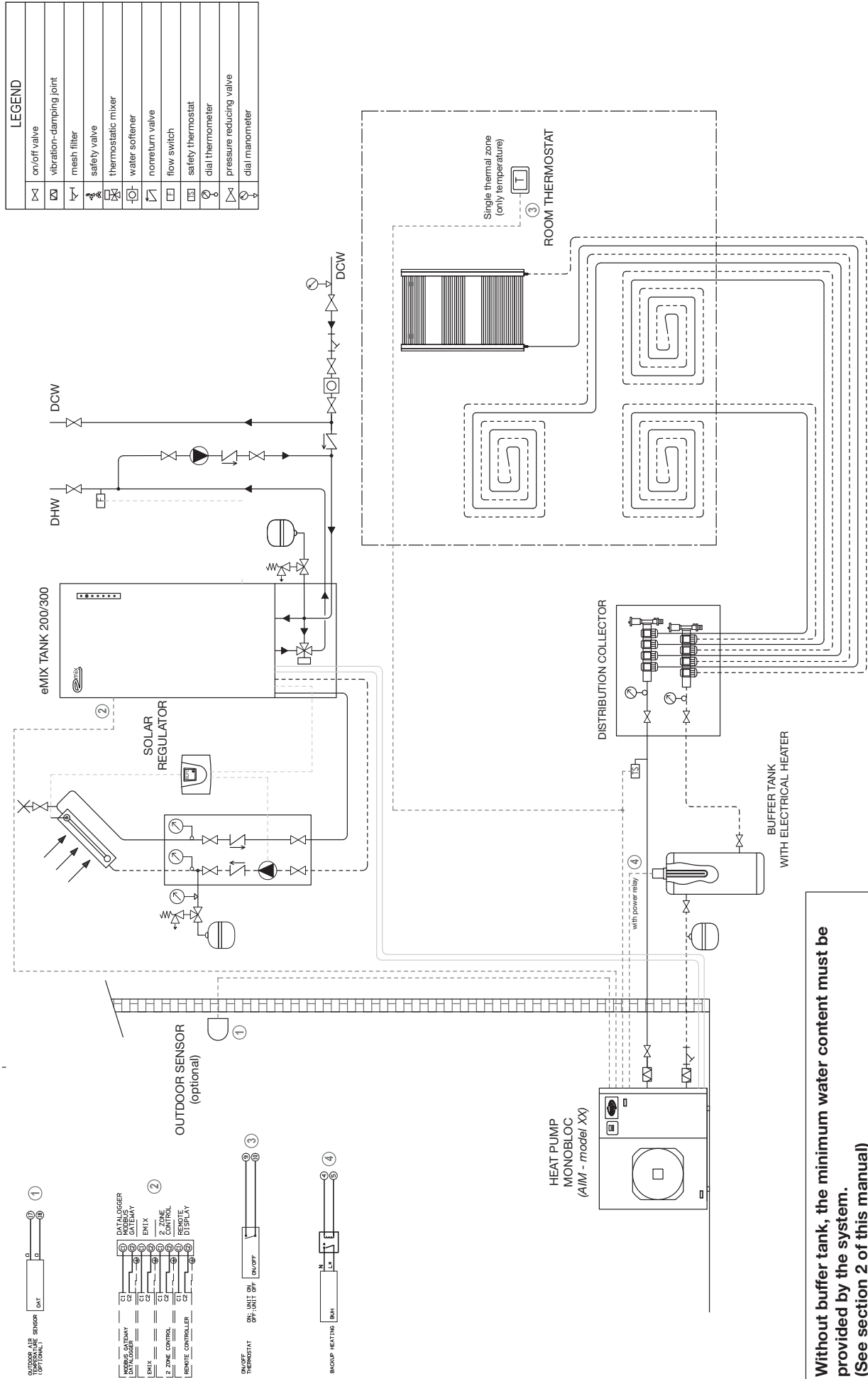

**Without buffer tank, the minimum water content must be provided by the system.
(See section 2 of this manual)**

ONLY HEATING, SINGLE ZONE. DHW PRODUCTION WITH EMIX AND TANK.

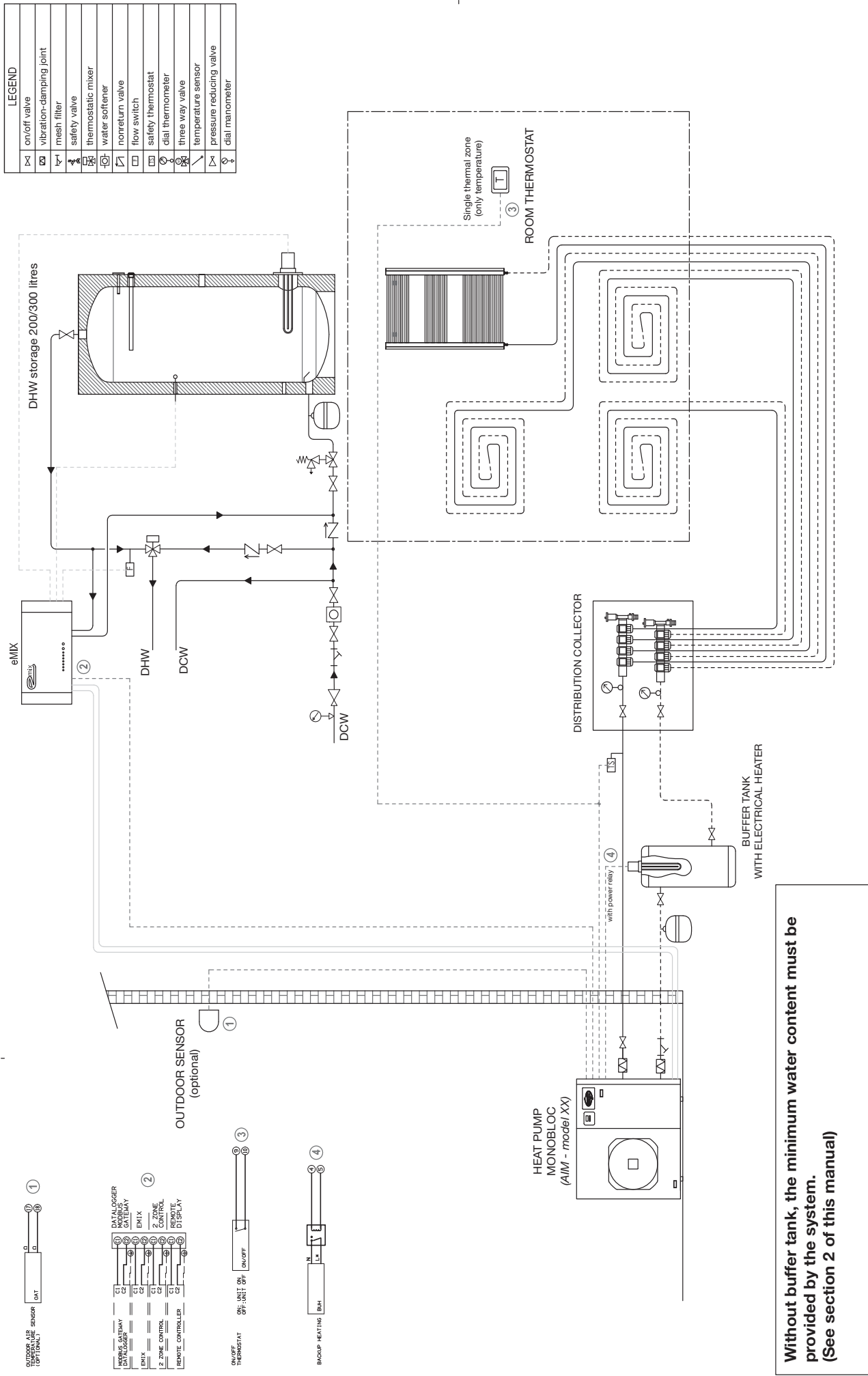

Without buffer tank, the minimum water content must be provided by the system. (See section 2 of this manual)

**ONLY HEATING, SINGLE ZONE.
DHW PRODUCTION WITH "DHW KIT".**

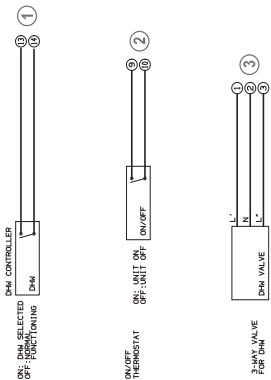
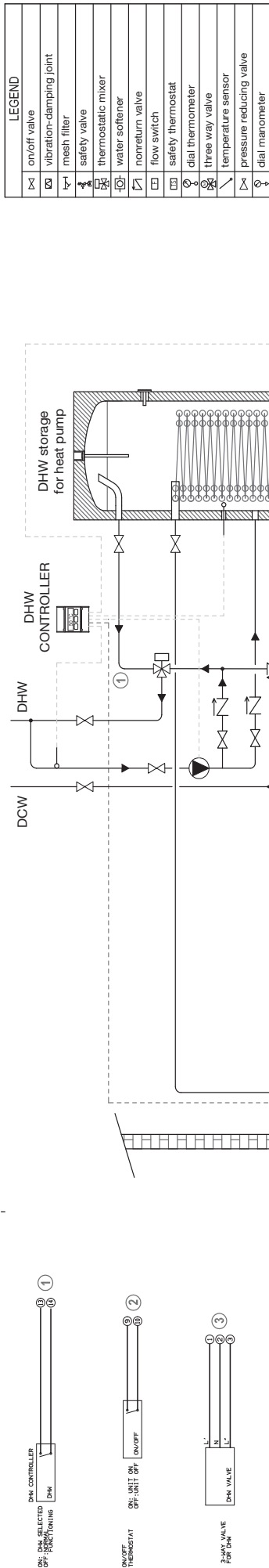

LEGEND

	on/off valve
	vibration-damping joint
	mesh filter
	safety valve
	thermostatic mixer
	water softener
	nonreturn valve
	flow switch
	safety thermostat
	dial thermometer
	three way valve
	temperature sensor
	pressure reducing valve
	dial manometer

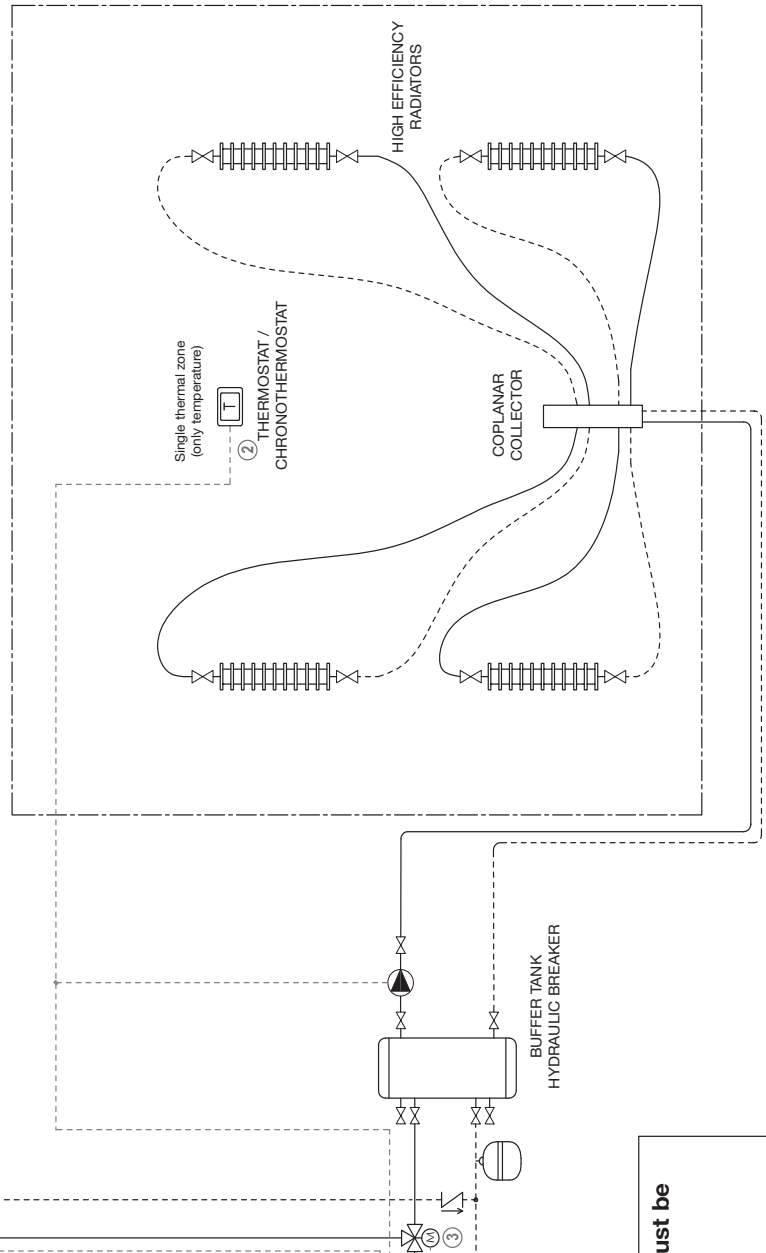

**Without buffer tank, the minimum water content must be provided by the system.
(See section 2 of this manual)**

HEATING AND COOLING, MULTI ZONE. USE OF BOILER AS BACKUP HEATING. DHW PRODUCTION WITH BOILER.

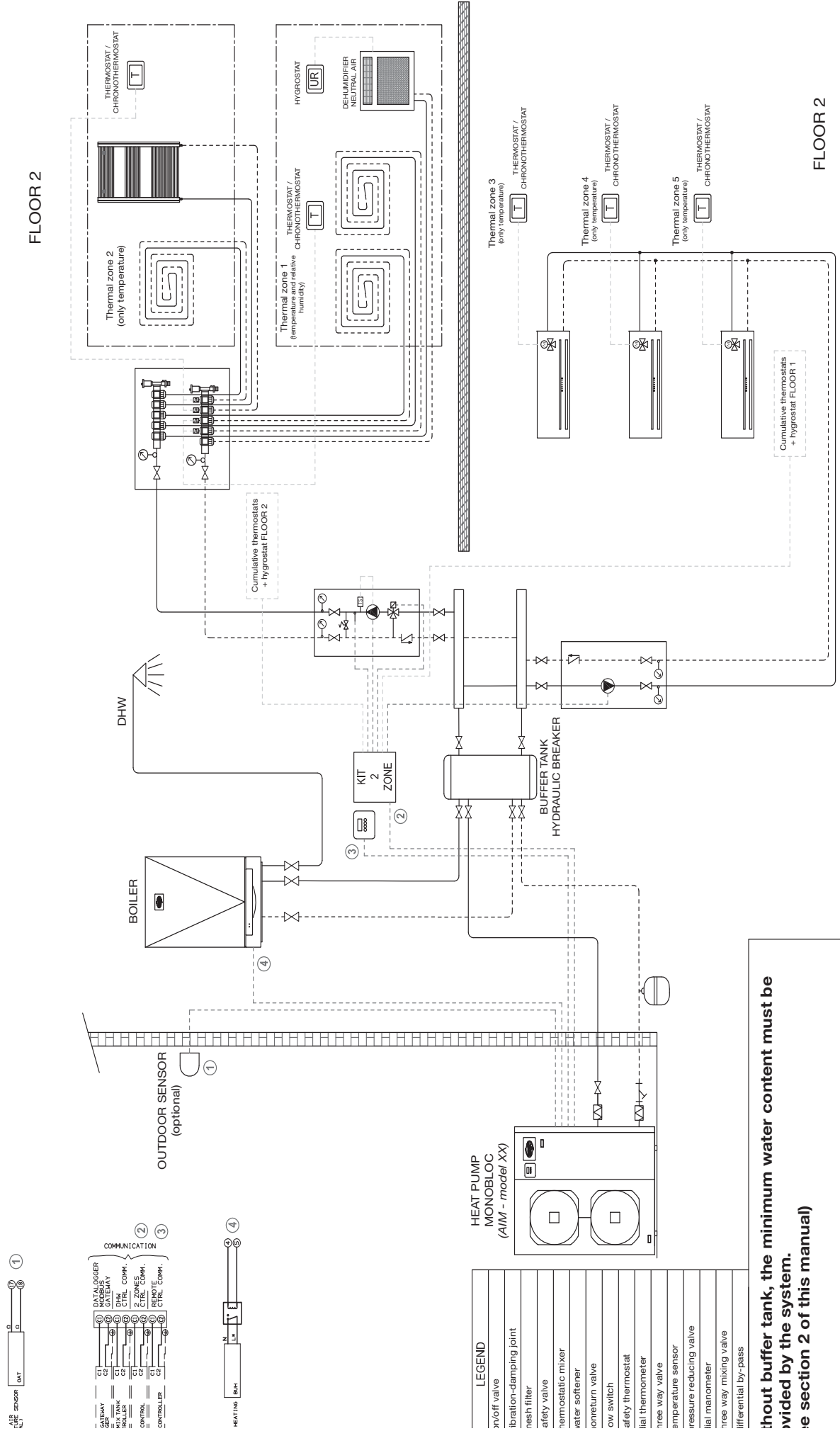

Without buffer tank, the minimum water content must be provided by the system. See section 2 of this manual

IMPORTANT NOTE

Before carrying out any work on the installation, make sure that it is switched off and that access to it is prevented.

Any work must be carried out by personnel qualified and authorised to work on this type of unit.

7.1 - PRELIMINARY CHECKS**7.1.1 - HYDRAULIC CIRCUIT**

- Hydraulic couplings correctly tightened.
- Hydraulic circuit operating correct:
 - Air purge from circuits.
 - Position of valves.
 - Hydraulic pressure (1.5 to 2.0 bar).
- Water-tight hydraulic circuit.
- Water quality:
 - In order for the heat pump to operate under good conditions and provide optimum performance, it is essential to ensure that the system's water circuit is clean. If the water circuit becomes clogged, this will significantly affect the machine's performance. The circuit must therefore be cleaned with suitable products in compliance with current standards as soon as it is installed, both for new and renovation work.

We recommend the use of products which are compatible with all metals and synthetic materials and approved by official bodies.

The water must adhere to the following characteristics:

- pH: 7 to 9.
- TH: 10 to 20°F.
- Dry material in suspension: < 2 g/l.
- Granulometry: < 0.4 mm.
- Chloride: 50 mg/l maximum.
- Conductivity: 150 to 350 $\mu\text{S}/\text{cm}^2$.
- Fibre: no fibres.

Any disorder which may occur on our machines due to the poor quality of the fluid in the installation will not be covered by the warranty.

IMPORTANT:

If anti-freeze is added, use monopropylene glycol. Antifreeze rate must be in accordance with the supplier's recommendation (normally at least 20%) in order to avoid any risk of corrosion.

Note: The injection of antifreeze in the circuit must not be done at the pump suction of the unit and the pump must not be used as a mixer. This is to prevent chemical alterations of the pump due to antifreeze concentration.

7.1.2 - REFRIGERANT SYSTEM (EMIX/EMIX TANK)

- Check carefully for any leaks.

7.1.3 - ELECTRICAL SYSTEM

- The power cables are well fixed to their connection terminals. Terminals that are poorly tightened may cause overheating and malfunctions.
- The electric cables are well insulated from any sections of sheet metal or metal parts which could damage them.
- The power cables and the low voltage cables (thermostat, probes) are properly separated.
- The unit is earthed.

7.1.4 - OTHER

- Overall good condition of the unit.
- No tools or other foreign objects inside the unit.

7.2 - JUMPERS/SWITCH SETTING

7.2.1 - MAIN BOARD

AIM06EMX

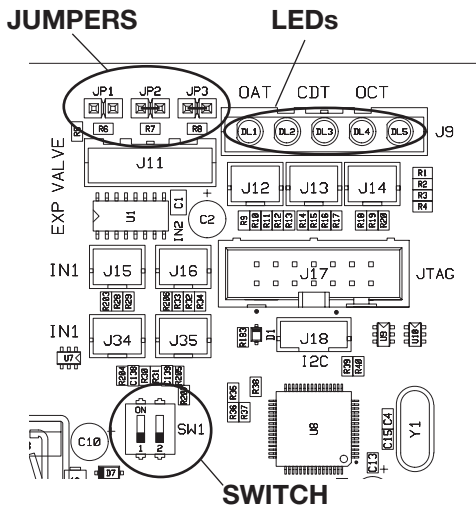

AIM08EMX / AIM11EMX

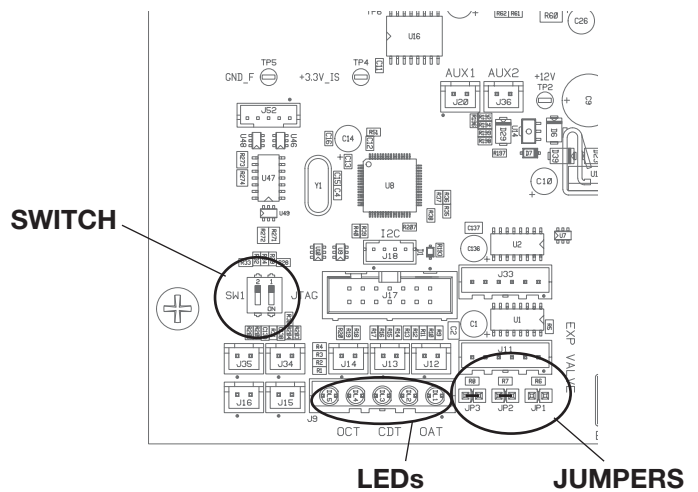

AIM11EMX3PH / AIM14EMX3PH

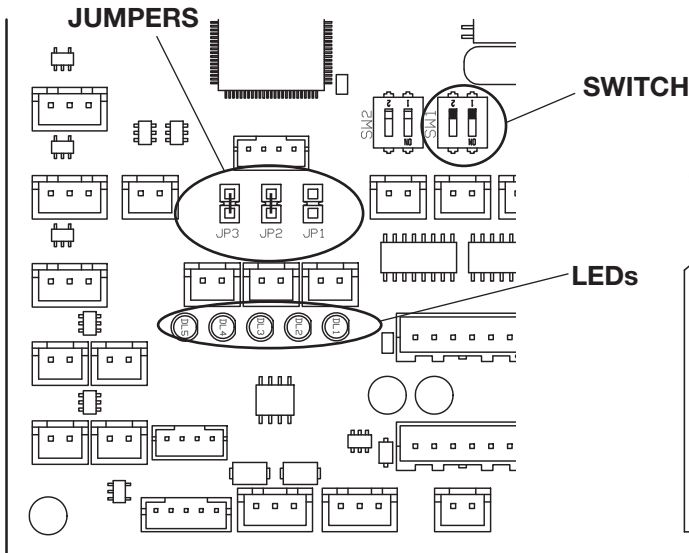

AIM14EMX

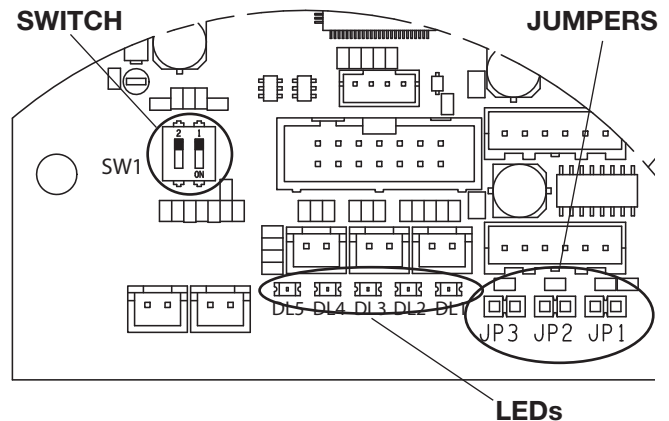

JUMPERS

JP1

Internal use. Do not change factory setting (OPEN). If changed, the unit will not run properly.

JP2 - DEFROST TYPE SELECTION

CLOSED: the unit will automatically select between reverse-cycle defrost and continuous defrost (FACTORY SETTING).

OPEN: the unit will run only reverse-cycle defrost.

JP3 - ENABLING COOLING MODE

CLOSED: the unit will run in heating mode only (FACTORY SETTING).

OPEN: the unit can run in heating and cooling mode.

SWITCH

SW1 : Internal use. Leave the setting OFF/OFF

LEDs

DL1 : ON: presence of mains voltage.
OFF: absence of mains voltage or defective board.

DL2 : ON: running unit.
OFF: stand-by unit.

OTHER INFORMATION ABOUT DL1/DL2/DL3/DL4/DL5: see diagnostic table

7.2.2 - CONTROL PANEL/DISPLAY

See manual “Control panel /display” for the system parameterisation.

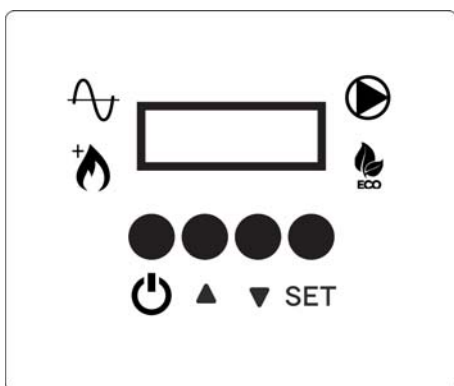

7.2.3 - INPUT/OUTPUT BOARD

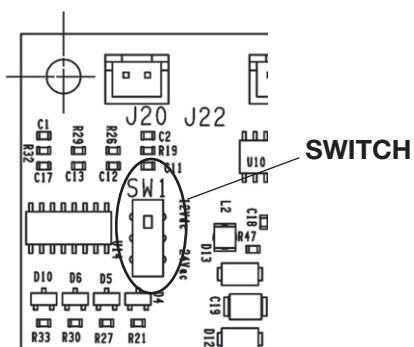

SWITCH

SW1 : DEFAULT: 12 Vdc.

THERMOSTAT TYPE SELECTION:

12 Vdc: Dry contacts

24 Vac: Contacts 24 Vac

7.3 - ADDITIONAL HYDRAULIC CIRCUIT VERIFICATIONS (USING CONTROL PANEL)

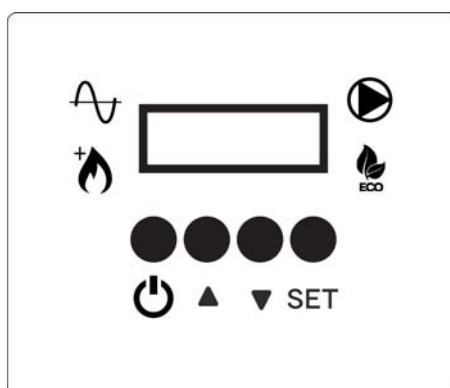

7.3.1 - FORCED START-UP OF CIRCULATION PUMP

To carry out the latest hydraulic circuit tests, start the circulation pump (forced start-up) as follows (under voltage system):

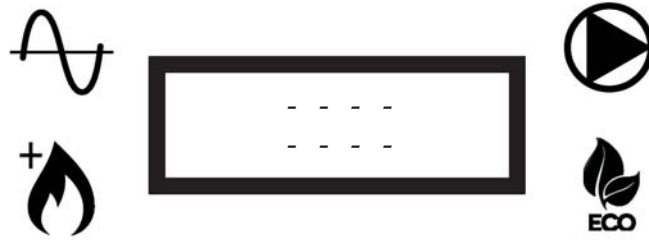

- Turn on the display while holding down the **ON/OFF** button  for 3 seconds:

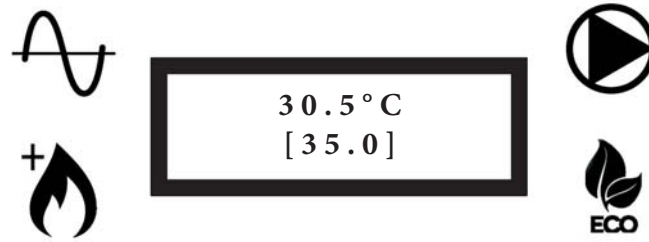

- Press the **SET** button once to enter the menu (first level):

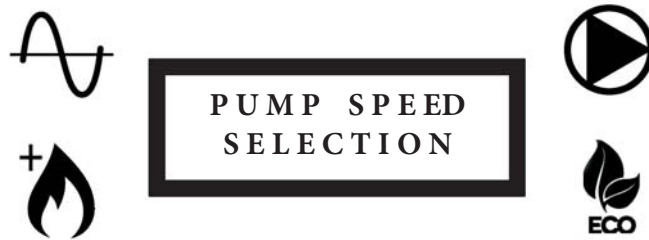

- Press the **SET** button once to enter the circulation pump speed setting menu:

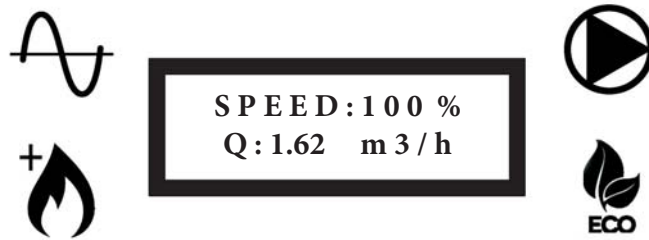

The pump speed is set to 100% by default.

Wait for the pump to start and the re-reading of the flow in the second line of the screen is stable.

7.3.2 - CHECKS

With the pump running, perform the following checks:

- Hydraulic circuit air bleed: operate the pump at 100% in manual mode) for as long as it takes to completely purge the circuit air.
- Hydraulic pressure between 1.5 and 2.0 bar
- Hydraulic circuit water flow (see below)
- Return water temperature of the system

NOTES

- **PUMP RELEASE**

At the first start-up or after long periods of inactivity of the unit, the pump could be mechanically blocked for limestone or other reasons.

To unlock the pump, set the speed to 100% (in manual mode) and run the pump for at least 10 minutes; it will unlock automatically.

After the pump has been released, let it run in any case again all the time necessary (always at 100%) to purge well all the air of the system; then adjust the water flow as explained below.

- **MINIMUM RETURN WATER TEMPERATURE** (see section of user manual "RETURN WATER MINIMUM TEMPERATURE PROTECTION")

A water temperature safety (system return) prevents the heat pump from operating if the temperature is lower than the heating authorization threshold with the heat pump (parameter 52). In this case, only the electric backup heating is authorized to raise the water temperature and allow the heat pump to operate, at any external temperature.

For this reason, the heat pump stops and the display will show the writing: **RWT < P52**

- **STOP THRESHOLD OF OUTDOOR AIR TEMPERATURE** (see section of user manual "OPERATING RANGE OF HEAT PUMP/BACKUP HEATING")

The operation of the heat pump is prevented if the outside temperature is below the stop threshold (parameter 40). Only the backup heating is authorized.

7.3.3 - WATER FLOW REGULATION PROCEDURE

The heat pump is equipped with a variable speed pump adjustable by a control system.

From the previous menu (pump speed setting) you can set pump speed during normal operation and re-read the water flow at the set speed.

To change the pump speed, press ▲ or ▼ buttons until the desired flow rate is reached. After any change, wait a few seconds for re-reading the flow to be stable.

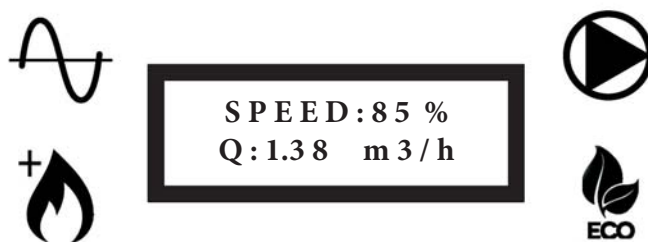

- Change the pump speed to obtain, depending on the application, the rated working capacity according to the following table:

Application	Water outlet t.	CAPACITY			
		AIM06	AIM08	AIM11	AIM14
Radiant surface	35°C	1.00 m ³ /h	1.39 m ³ /h	1.75 m ³ /h	2.34 m ³ /h
Fan coil	45°C	0.79 m ³ /h	1.20 m ³ /h	1.75 m ³ /h	2.34 m ³ /h
Low temperature radiators	55°C	0.45 m ³ /h	0.64 m ³ /h	0.80 m ³ /h	1.10 m ³ /h

7.3.4 - CHECKING THE PRESSURE LOSSES

With the pump running at the set speed, compare the reread flow with the following curves to determine the system pressure losses and compare them with the calculations made during the installation of the system.

AIM06

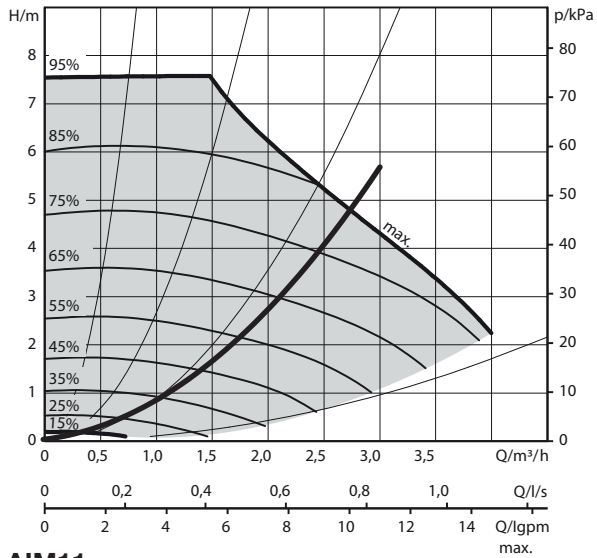

AIM08

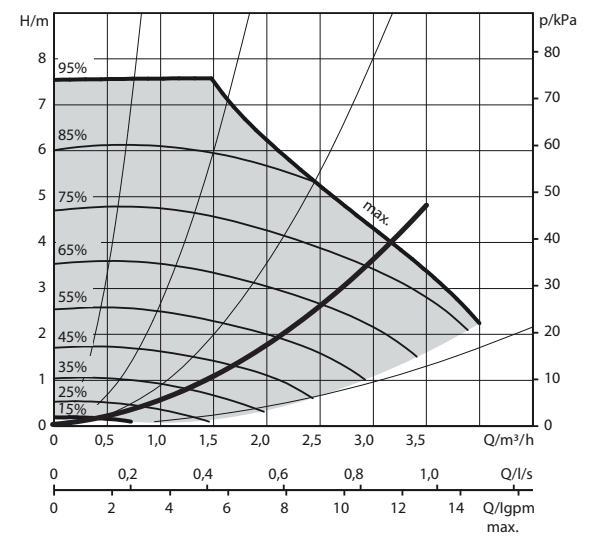

AIM11

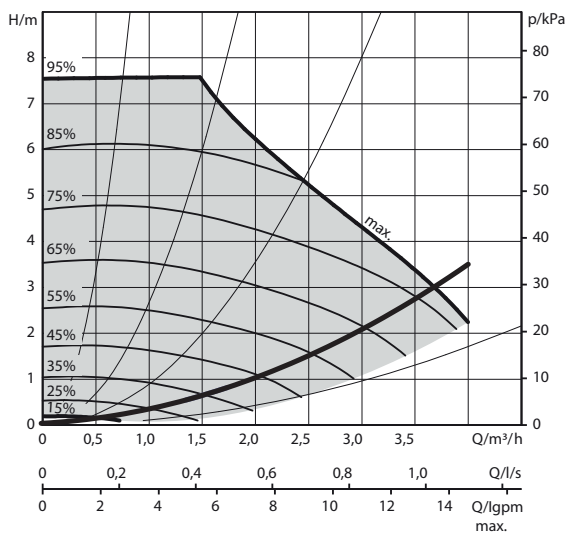

Example of calculation for floor system with AIM08:

- Set the pump speed to re-read a capacity of 1.39 m³/h (see table).
- On the AIM08 chart, cross the vertical line corresponding to 1.39 m³/h with the pump curve corresponding to the % of the set speed and the curve of the unit pressure losses.
- The system pressure losses correspond to the pressure losses of the pump curve less the unit pressure losses. In our example, the pressure losses are 48-9 = 39 kPa.

AIM14

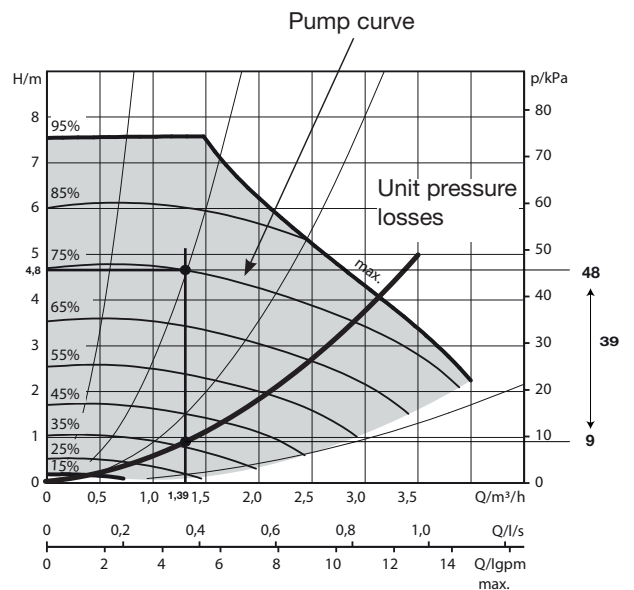
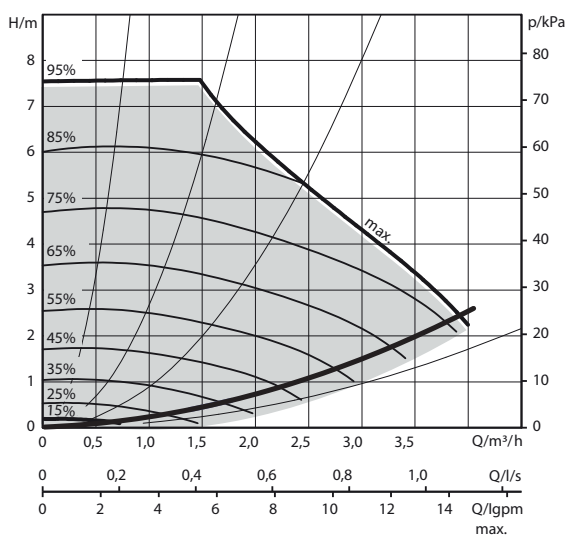

- Once the checks have been completed, press the  button until you return to the main menu.

7.4 - STARTING

- Turn on the system five hours before start-up in order to preheat the compressor housing.
- The system can only be started by authorized service centers.
- Fill in the required starter form attached.

8 - MAINTENANCE INSTRUCTIONS

IMPORTANT NOTE

- **Before doing any work on the installation, make sure it is switched off and all power supplies locked out.**
- **Also check that the capacitors are discharged.**
- **Any work must be carried out by personnel qualified and authorised to work on this type of machine.**
- **Prior to all maintenance and servicing on the refrigerating circuit, one must first shut down the unit then wait a few minutes before installing temperature or pressure sensors. Certain equipment, such as the compressor and piping, may reach temperatures above 100°C and high pressures may lead to serious burns.**

8.1 - GENERAL MAINTENANCE

All equipment must be properly maintained in order to provide optimum performance over time. Faulty maintenance can result in the cancellation of the product guaranty. Depending on the products, maintenance operations consist in the cleaning of filters (air, water), internal and external exchangers, casings, and the cleaning and protection of condensate tanks. Treating odours and the disinfection of room surfaces and volumes also contributes to the cleanliness of the air breathed by users.

- **Carry out the following operations at least once a year** (the frequency depends on the installation and operating conditions):
 - Check for leaks on the refrigerating circuit.
 - Check for traces of corrosion or oil stains around the refrigerating components.
 - Inspect the composition and the condition of the coolant and check that it does not contain traces of refrigerating fluid.
 - Cleaning the exchangers.
 - Checking the wear parts.
 - Checking the operating instructions and points.
 - Check the safety devices.
 - De-dusting the electrical equipment cabinet.
 - Checking that the electrical connections are secure.
 - Checking the earth connection.
 - Check the hydraulic circuit (clean the filter, water quality, purge, flow rate, pressure, etc.).

8.2 - TROUBLESHOOTING RECOMMENDATIONS

- All maintenance and servicing operations on the refrigerating circuit must be conducted in accordance with standard trade practices and safety rules: recovery of the refrigerant, inert shielded (nitrogen) brazing, etc...
- All brazing operations must be conducted by qualified personnel.
- This unit is equipped with pressurised equipment, for example piping.
Use only genuine parts listed in the spare parts list for replacing defective refrigeration components.
- Leak detection, in the case of pressure testing:
 - Never use oxygen or dry air, as the risk of fire or explosion is present.
 - Use dehydrated nitrogen or a nitrogen and refrigerant mix indicated on the manufacturer's plate.
 - For units equipped with pressure gauges, the test pressure must not exceed the gauges' maximum allowable pressure rating.
- All part replacement with other than genuine parts, all modifications of the refrigerating circuit, all replacement of refrigerant by a fluid other than that indicated on the manufacturer's plate, all use of the unit outside the application limits defined in the documentation, shall result in the cancellation of PED EC marking compliance which shall fall under the liability of the individual who carried out these modifications and the void warranty.
- The technical information, relative to the safety requirements of the various applicable directives, is indicated on the manufacturer's plate of the unit and mentioned on the 1st page of this manual.

Symbols of the components

CM	Compressor
CWH	Condensation water resistance
ICP	Gas pressure sensor
LP	Low pressure switch
RWT	Return water temperature sensor
SWT	Supply water temperature sensor
OAT	Outdoor air temperature sensor
ICT1	Outlet sensor (HEAT) / inlet sensor (COOL) plate exchanger
ICT2	Inlet sensor (HEAT) / outlet sensor (FREDDO) plate exchanger
OCT	Outdoor coil temperature sensor
CDT	Compressor discharge temperature sensor
CTST	Compressor top shell temperature sensor
ICP	Condensation pressure sensor (HEAT) / evaporation pressure sensor (COOL)
DHW	Domestic hot water

Colour of the wires

BLK	Black
BRN	Brown
BLU	Blue
GRN	Green
GRY	Grey
ORG	Orange
PNK	Pink
RED	Red
VLT	Violet
WHT	White
YEL	Yellow

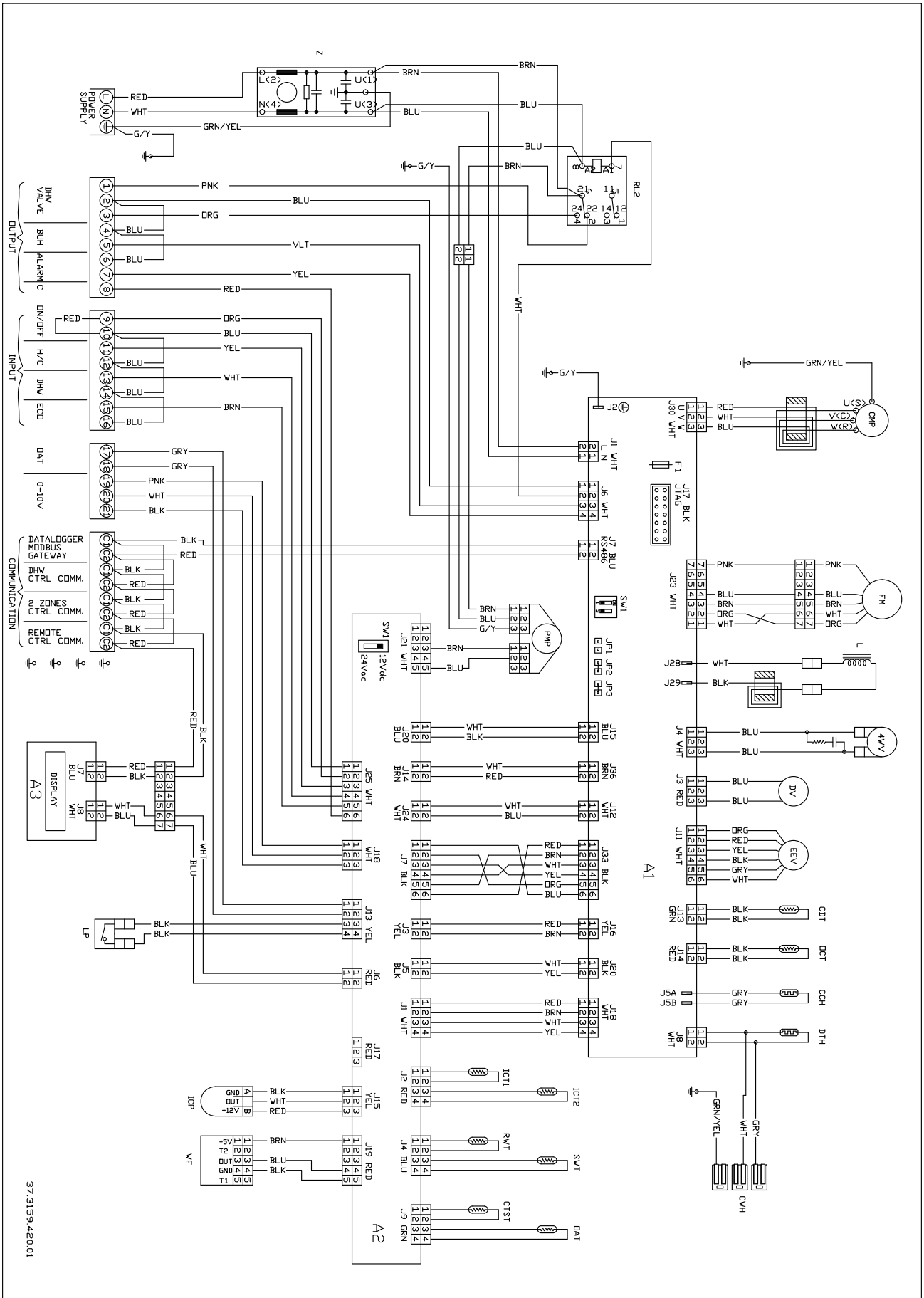

37.3159.4B0.01

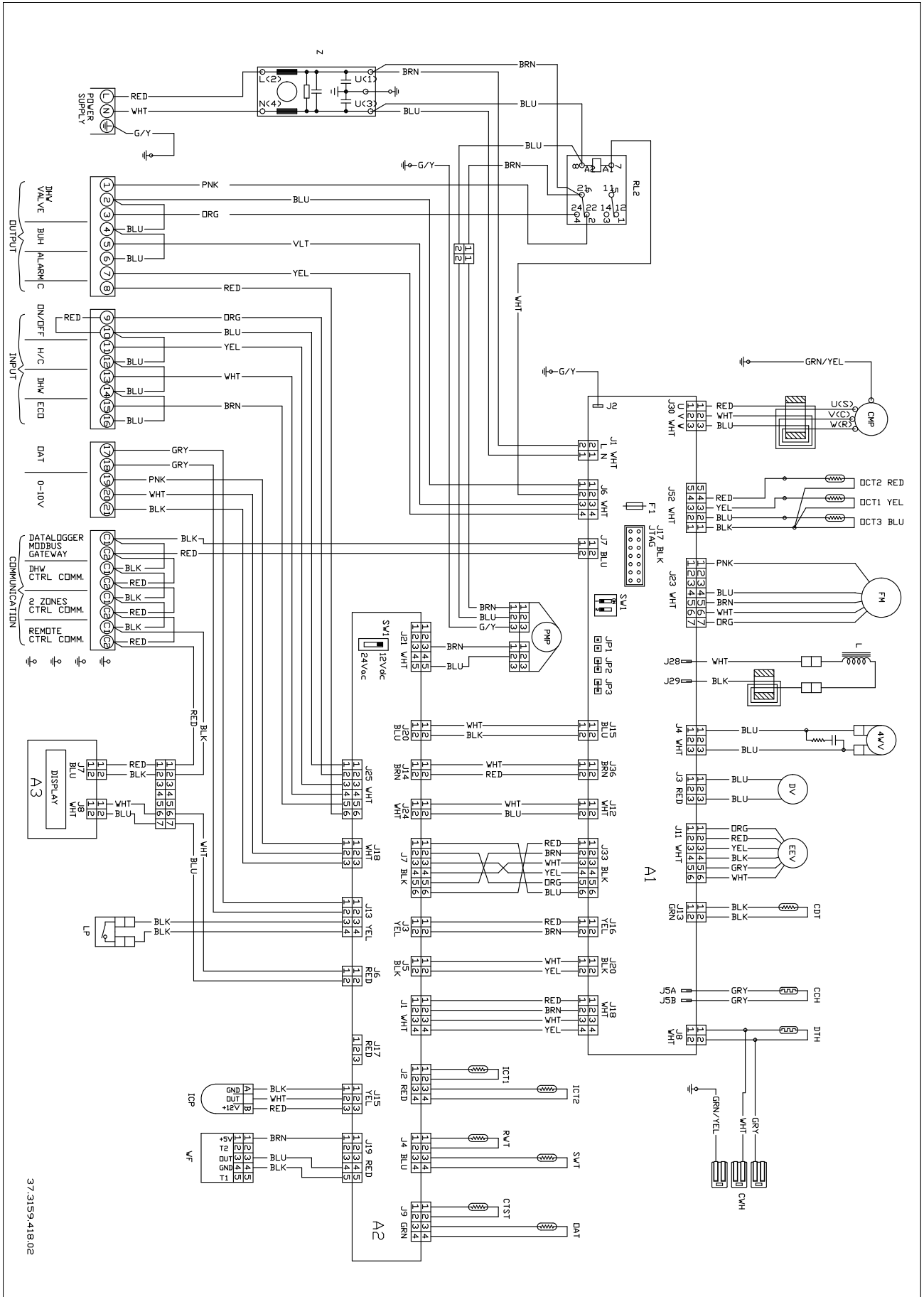

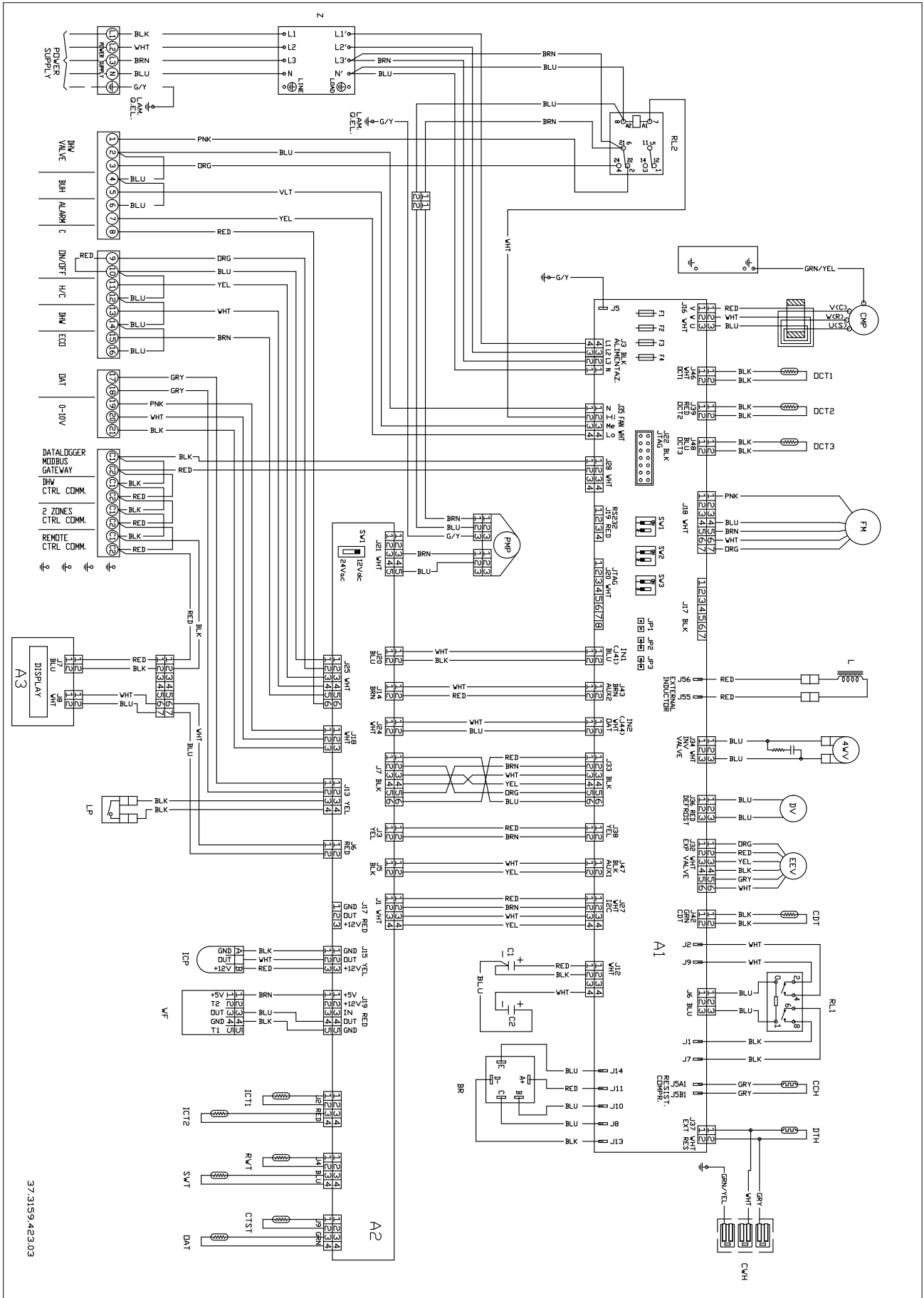

37.3159.423.03

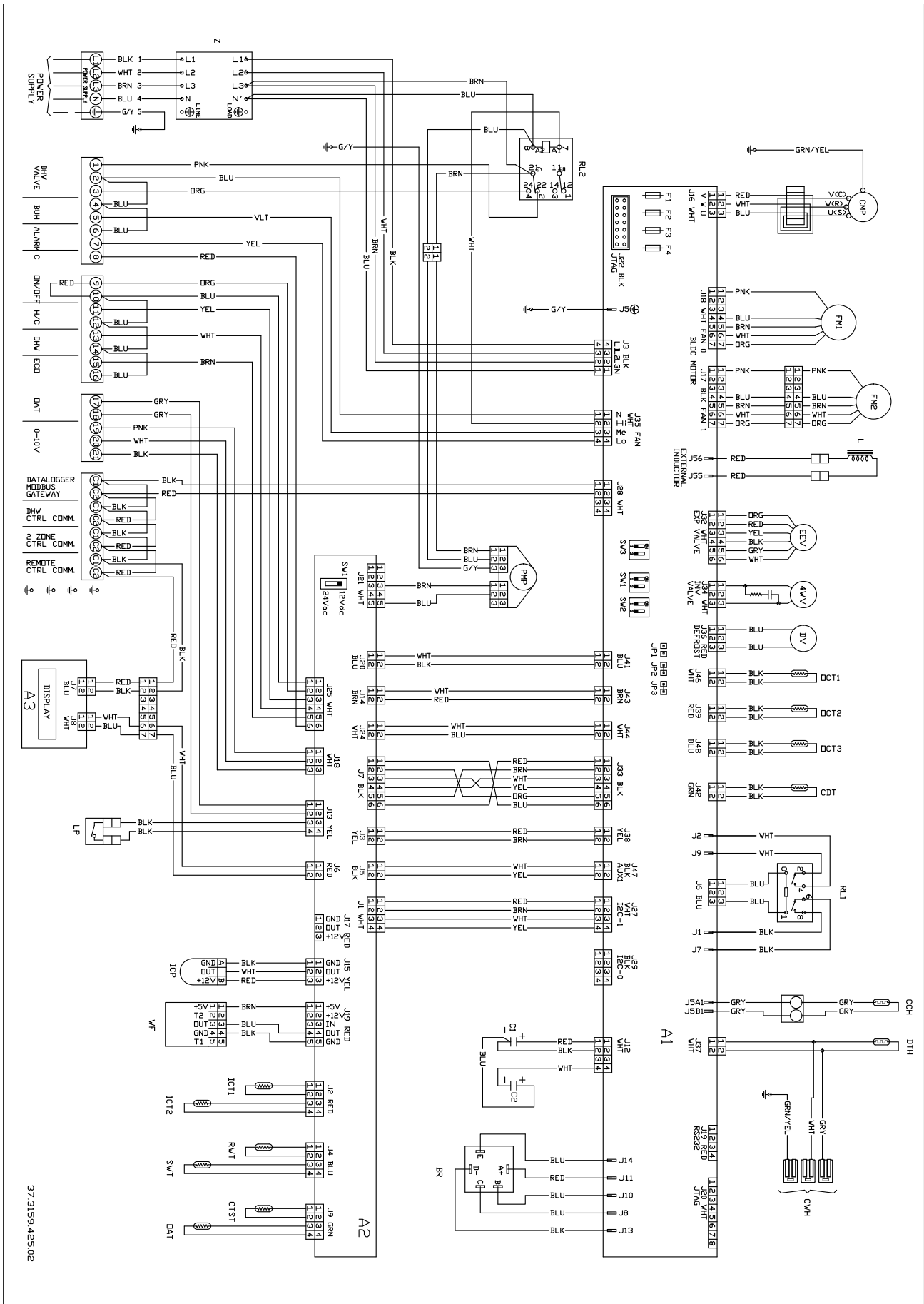

37.3159.425.02

10 - AUTO-DIAGNOSIS TABLE

EN



CAUTION

Disconnect power and wait that all LEDs are OFF before servicing on the electrical box.

X LED OFF

O LED ON

⚡ LED BLINKING

DISPLAY		LEDs ON BOARD					DESCRIPTION
101	CHECK SENSOR	⚡	⚡	⚡	⚡	X	Test mode error
100	INSTALL. ERR	⚡	X	⚡	X	⚡	Communication error with DHW or 2 zones controller
18	ICP DEFECT	⚡	⚡	X	X	⚡	Refrigerant pressure sensor not connected
17	HIGH PRESS	X	⚡	⚡	X	⚡	High pressure error
16	LOW PRESS	⚡	X	X	⚡	⚡	Low pressure error
15	CTST DEFECT	X	⚡	X	⚡	⚡	CTST sensor damaged or not connected
14	CDT DEFECT	⚡	X	⚡	X	X	CDT sensor damaged or not connected
13	OAT DEFECT	X	⚡	X	⚡	X	OAT sensor damaged or not connected
12	OCT DEFECT	X	X	⚡	X	⚡	OCT sensor damaged or not connected
11	ICT2 DEFECT	X	X	X	⚡	X	ICT2 sensor damaged or not connected
10	ICT1 DEFECT	X	X	⚡	X	X	ICT1 sensor damaged or not connected
9	SWT DEFECT	X	⚡	X	X	X	SWT sensor damaged or not connected
8	RWT DEFECT	⚡	X	X	X	X	RWT sensor damaged or not connected
7	COMP PROTECT	X	X	X	⚡	⚡	Compressor error
6	OVERTEMP PCB	X	X	⚡	⚡	X	PCB overtemperature (compressor module)
5	FAN ERROR	X	⚡	⚡	X	X	Fan motor error
4	COMM ERROR	⚡	⚡	X	X	X	PFC protection or communication error on IR
3	COMM ERROR	X	X	⚡	⚡	⚡	Communication error with display
1	NO FLOW	⚡	⚡	⚡	X	X	No water flow
ERROR CODE		DL5	DL4	DL3	DL2	DL1	
		O	O	O	O	O	



INFORMATION FOR CORRECT DISPOSAL OF THE PRODUCT IN ACCORDANCE WITH THE EUROPEAN DIRECTIVE 2012/19/EU

At the end of its working life this equipment must not be disposed of as an household waste. It must be taken to special local community waste collection centres or to a dealer providing this service. Disposing of an electrical and electronic equipment separately avoids possible negative effects on the environment and human health deriving from an inappropriate disposal and enables its components to be recovered and recycled to obtain significant savings in energy and resources. In order to underline the duty to dispose of this equipment separately, the product is marked with a crossed-out dustbin.

argoclima s.p.a.

Via Alfeno Varo, 35 - 25020 Alfianello - BS - Italy

Tel. +39 0331 755111 - Fax +39 0331 755501

www.argoclima.com